



# HOSHIZAKI

## IM-240XNE-HC-32

### Cuber, Modular

Production Capacity (kg/24h) approx. (AT 10°C, WT 10°C): 190



PRODUCT SERIES: IM  
ITEM NUMBER: M071-D105  
COUNTRY OF ORIGIN: UK

Hoshizaki IM-240XNE-HC-32 is modular and stackable (extension) ice maker producing up to 190 kg of cube ice per 24 hours. This model is compatible with our storage bins.

Ice cube dimensions and weight - disclaimer: The drawing is for illustration purposes only. Cube size and weight may differ due to local installation conditions.

- Ice making system with an automatic rinse cycle
- Each ice cycle is made with fresh water
- Closed water circuit for contamination protection
- Closed Cell System helps produce compact, hard and geometrically perfect ice
- Electronic controller
- System comes with a magnetic water pump that has no direct coupling, which prevents any leakage
- Cleanable air filter
- Stainless steel frame inside

ICE TYPE: Extra large cubes - 32

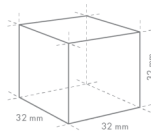

Cube Size: **XL-32**  
Weight: 31 g

**WARRANTY PERIOD**  
**2 Years on Parts & Labour**

**EXTERIOR**  
Stainless steel AISI 430, Galvanized steel (Rear)

Refrigerant: R290 / Refrigerant (kg): 0.147 / CO2 equivalent (kg): 0.441

**OPERATING CONDITIONS**  
Ambient Temp.: 1-40°C, Water Supply Temp.: 5-35°C, Water Supply Pressure: 0.07-0.8MPa (0.7-8bar), Voltage Range: Rated Voltage ±6%

**ACCESSORIES INCLUDED**  
Scoop, installation kit, ice chute

**OPTIONAL ACCESSORIES**  
4HC-H water filtration

**CORRESPONDING WATER FILTERS**  
4HC-H Twin Water Filter, 4HC Replacement Cartridge

**CORRESPONDING BIN(S)**  
B-340SA, F-1025-52S, F-600-42S, F-650-44S, F-950-48S

**CORRESPONDING TOP KITS**  
TK-48 for B-340SA (optional, not required), TK-IMD2 for B-340SA

#### CERTIFICATIONS





# HOSHIZAKI

## IM-240XNE-HC-32

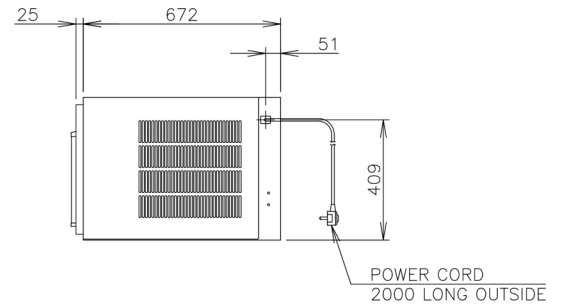
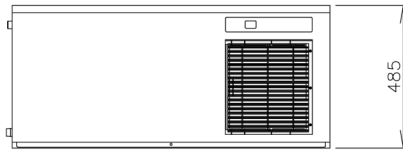
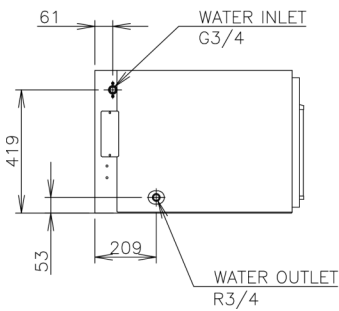
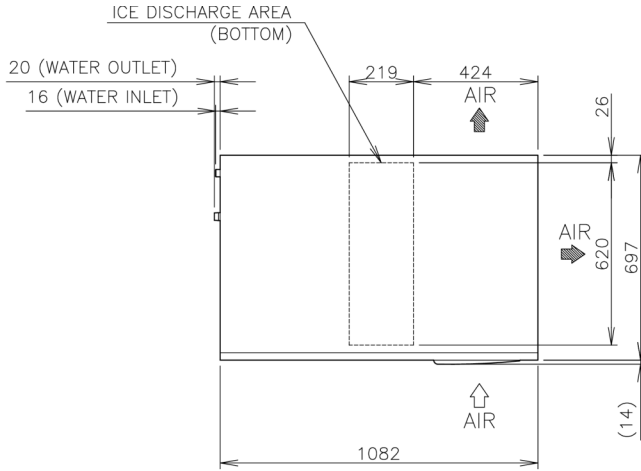

### TECHNICAL SPECIFICATIONS

Cooling System	Production Capacity (kg/24h) approx. (AT 10°C, WT 10°C)	Production Capacity (kg/24h) approx. (AT 21°C WT 15°C)	Production Capacity (kg/24h) approx. (AT 32°C WT 21°C)	Power Supply	Electrical Circuit Breaker Protection (A)	Electric Consumption (kW)	Water Consumption (m3/24h) approx. (AT 10°C WT 10°C)	Heat Rejection (AT 32°C, WT 21°C) (kW)
Air Cooled	190	175	145	1/220 - 240V/50Hz	5	0.93	0.53	2.33

### SHIPPING SPECIFICATIONS

Dimensions W x D x H (mm)	Net Weight (kg)	Dimensions, Packed, W x D x H (mm)	Gross Weight, Packed (kg)
1082 x 697 x 485	78	1196 x 825 x 640	93

Disclaimer: Every effort has been made to ensure that the information contained in this spec sheet is accurate at the time of publishing. Hoshizaki Europe BV assumes no responsibility or liability for typographical errors or omissions or for any misinterpretation of the information within the publication and reserves the right to change without notice.

Please observe: This type of icemaker is on special order only. Please take longer lead times into consideration.



Hoshizaki Belgium [info@hoshizaki.be](mailto:info@hoshizaki.be)  
 Hoshizaki Denmark [info@hoshizaki.dk](mailto:info@hoshizaki.dk)  
 Hoshizaki Deutschland [vertrieb@hoshizaki.de](mailto:vertrieb@hoshizaki.de)  
 Hoshizaki France [info@hoshizaki.fr](mailto:info@hoshizaki.fr)  
 Hoshizaki Iberia [info@hoshizaki.es](mailto:info@hoshizaki.es)  
 Hoshizaki Italia [commerciale@hoshizaki.it](mailto:commerciale@hoshizaki.it)  
 Hoshizaki Middle East [sales.ex@hoshizaki-europe.com](mailto:sales.ex@hoshizaki-europe.com)

Hoshizaki Netherlands [info@hoshizaki.nl](mailto:info@hoshizaki.nl)  
 Hoshizaki Norge [salg@hoshizaki.no](mailto:salg@hoshizaki.no)  
 Hoshizaki Sverige [orderSE@hoshizaki.dk](mailto:orderSE@hoshizaki.dk)  
 Hoshizaki UK [uksales@hoshizaki.uk](mailto:uksales@hoshizaki.uk)  
 Export countries [sales.ex@hoshizaki-europe.com](mailto:sales.ex@hoshizaki-europe.com)  
 Other countries [sales.ex@hoshizaki-europe.com](mailto:sales.ex@hoshizaki-europe.com)

[www.hoshizaki-europe.com](http://www.hoshizaki-europe.com)