

BUILT-IN APPLIANCES



CANDY
KNOWS HOW



CANDY



■ THE CANDY PHILOSOPHY

A real understanding of consumer requirements is central to Candy's ongoing research and development programme. By anticipating changes in taste and lifestyle Candy has translated research results into unique appliance innovations, producing kitchen appliances that are efficient, technically advanced and beautifully styled. Developed for today's lifestyle these new appliances will co-ordinate perfectly with contemporary as well as the more traditional kitchen designs and all come with a guarantee of satisfaction from a company that has a reputation for taking care of its customers.

The Candy logo is rendered in a bold, blue, 3D-style font. The letters are thick and have a slight shadow, giving them a three-dimensional appearance. The word "CANDY" is written in all capital letters, with a slight slant to the right. The background behind the letters is a light, hazy blue gradient.

■ CONTENTS



OVENS

Maxi Ovens	8
U•See Ovens	10
Plan Light Ovens	12
Built-in Warming Drawers	13
Plan Double Ovens	14
Gas Oven	16
Classic Oven	16
Built-in Microwave Ovens	16
Range Cookers	18
Duo range	20
Trio range	22



HOBS

Plan gas hobs	26
Classic gas hob	27
Plan gas hobs	27
Gas hobs	27
Electric hob	27
Induction hobs	28
Hi-light Ceramic hobs	29
Domino hobs	30



HOODS

Island hoods	34
Decor hoods	34
Plan decor hoods	35
Chimney hoods	36
Integrated hoods	37
Canopy hoods	37
Conventional hoods	37



DISHWASHERS

Fully integrated dishwashers	40
Semi Integrated Dishwasher	41
Fully integrated Slimline dishwasher	41



LAUNDRY

Fully integrated washer dryers	42
Fully integrated washing machines	43



REFRIGERATION

Side by side fridge freezer	46
Fully integrated fridge freezers	46
Fully integrated refrigeration	47
Built-in wine coolers	50

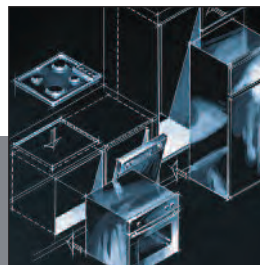

TECHNICAL SPECIFICATIONS

From page

51



OVENS

Candy's Plan range which includes single and double ovens combines the attraction of simple styling with the quality of a great brand. It's flat front styling, clean-cut lines and careful positioning of controls are in line with the latest trends in cooking design.



Energy Efficient

Candy Ovens offer outstanding performance as some are now rated A+, which means that they are 10% more efficient than the most efficient A rated oven.



Aqua Active Oven Cleaning System

The Aqua Active cleaning system helps to remove even the most stubborn burnt on food residues and grease spattering from the oven cavity.

It's quick and easy to use, simply pour around 300ml of water into the shallow well at the base of the oven cavity and select the Aqua Active cleaning programme on the dial. The oven is heated to a temperature of 90°C for a period of 30 minutes. When cool the oven can simply be wiped over with a cloth.

Catalytic Liners

Catalytic liners are available on some of the ovens in the Candy range and they work by attracting grease particles and food residues to the liners, these minute deposits are then carbonised by the heat from the oven, this makes them extremely easy to clean.



NEW OVEN DOOR DESIGN

Candy single ovens have a new full glass oven door for easy cleaning and a larger glass window for improved visibility.



SAFETY SHELF SYSTEM

The oven walls feature specially designed grooves that allow the shelves to slide more easily. The grooves also prevent the shelves from being pulled out completely.

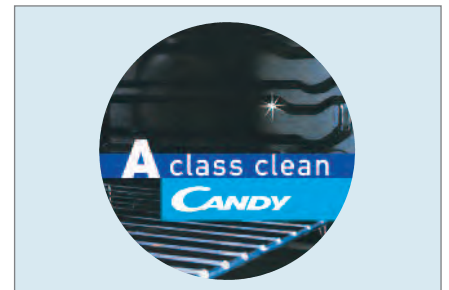

A CLASS CLEAN SYSTEM

The new A Class Enamel, smooth as glass, is completely water and dirt repellent. Its ultra smooth surface prevents dirt from adhering to the surface, and withstands corrosion from high sugar-content foodstuffs.



■ **LARGE CAPACITY MAXI OVEN**



With more than 45% more cooking capacity than a conventional oven, the Candy Maxi oven, is at 78 litres capable of cooking on 5 different levels at any one time, which is ideal if you are entertaining family or friends. The oven has a soft close door, which can be left to gradually close and its cool touch as well, so it's extremely safe if children are in the kitchen.

MAXI OVENS / PLAN RANGE



FXLP 649 MAXI MULTI-FUNCTION OVEN

7 functions > **multi-function oven** > side opening door > variable grill > touch control electronic programmer > catalytic liners > defrost function > pizza function > conventional cooking > fan cooking > **integral fan cooling system** > double glazed door > cool touch door > large 73 litre capacity > energy class A

-  Stainless steel (right hand hinged door) .FXLP 649RX
-  Stainless steel (left hand hinged door) ...FXLP 649LX

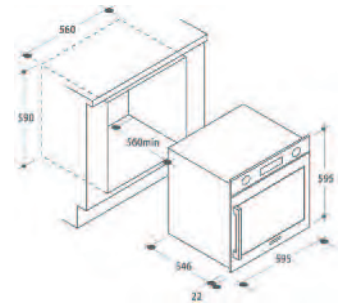

FXP 649X MAXI MULTI-FUNCTION OVEN

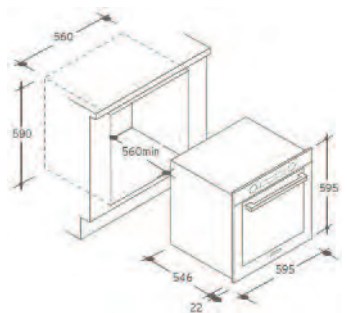

7 functions > **multi-function oven** > variable grill > touch control electronic programmer > catalytic liners > defrost function > pizza function > conventional cooking > fan cooking > **integral fan cooling system** > soft close door > double glazed door > cool touch door > large 73 litre capacity > energy class A

-  Stainless steelFXP 649X



FXP 609 MAXI MULTI-FUNCTION OVEN

7 functions > **multi-function oven** > variable grill > touch control electronic programmer > defrost function > conventional cooking > fan cooking > **integral fan cooling system** > soft close door > A class enamel - easy to clean oven interior > double glazed door > cool touch door > large 78 litre capacity > energy class A

-  Stainless steelFXP 609X
 -  Black/stainless steel*FXP 609NX
- * stainless steel knobs and handles only

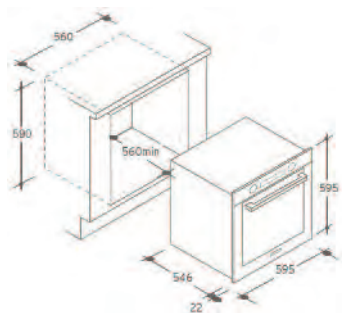



U-see lighting



Touch control electrical programmer



Oven control knob

■ U.SEE OVENS

U·SEE

Candy's innovative U-see technology combines outstanding performance with exceptionally low energy consumption. Fourteen ultra white lights on the oven door perimeter illuminate the whole cavity, providing perfect visibility throughout the entire oven. Usee ovens are A rated for energy efficiency and the LED lights use only 1wh of electricity compared to conventional oven lights that consume between 20wh -50wh.



FVPE 729X MULTI-FUNCTION OVEN

8 functions including soft cook > multi-function oven > variable grill > **14 U-see LED Lights** > AquaActiva cleaning system > defrost function > conventional cooking > fan cooking > pizza function > soft cook > A class enamel - easy to clean oven interior > safety shelf system > 2 shelves > 1 roasting tray / baking tray > double glazed door > 69 litre capacity > flat glass inner door > energy class A

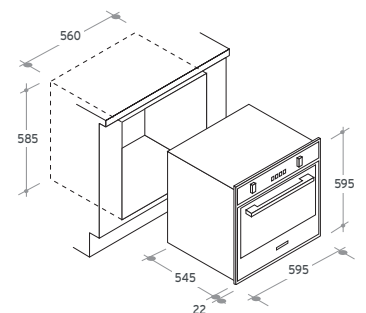

■ stainless steelFVPE 729 X

OVENS / PLAN LIGHT RANGE



FPE 609X MULTI-FUNCTION OVEN

7 functions > multi-function oven > AquaActiva cleaning system > electronic programmer > variable grill > fan cooking > pizza function > defrost function > **integral fan cooling system** > oven light > A class enamel - easy to clean oven interior > safety shelf system > 2 shelves > 1 roasting tray/grill pan > 65 litre capacity > energy class A+

■ stainless steelFPE 609X

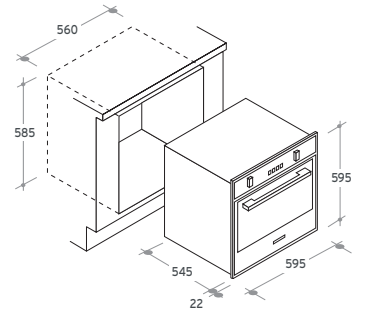

FPE 409X FAN OVEN

Electronic LED Programmer > fan cooking > fan grilling > variable grill > defrost function > integral fan cooling system > A class clean enamel - easy to clean oven interior > safety shelf system > 2 shelves > 1 roasting tray/grill pan > oven light > double glazed door > 65 litre capacity > energy class A

■ stainless steelFPE 409X
 ■ blackFPE 409N
 ■ whiteFPE 409W

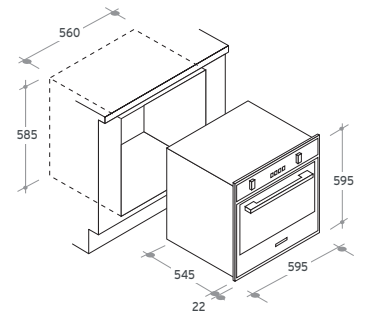

FPE 403 FAN OVEN

End of cooking timer > fan cooking > fan grilling > variable grill > integral fan cooling system > A class clean enamel - easy to clean oven interior > safety shelf system > 2 shelves > 1 roasting tray/grill pan > oven light > double glazed door > 65 litre capacity > energy class A

■ stainless steelFPE 403X
 ■ blackFPE 403N
 ■ whiteFPE 403W

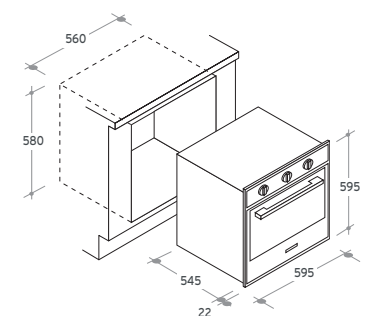

OVENS / PLAN LIGHT RANGE



FST 201 STATIC OVEN

3 functions > dual zone grill > oven light > A class enamel - easy to clean oven interior > safety shelf system > 2 shelves > 1 roasting tray/grill pan > double glazed door > 65 litre capacity > energy class A

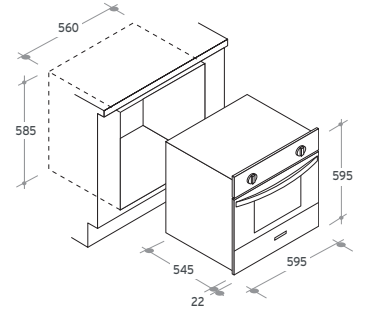

- stainless steelFST 201X
- blackFST 201N
- whiteFST 201W

WARMING DRAWER / WARMING DRAWER



RDCT 140/1MIN BUILT-IN WARMING DRAWER

Programmes : keep warm function, pre-heating crockery > temperature freely adjustable from 30°C to 80°C > stainless steel finish > anti slip mat > illuminated on/off switch > telescopic full-depth pull-out drawer > max capacity 25kg > max absorbed power 620W > external dimensions H 140 x W 594 x D 535

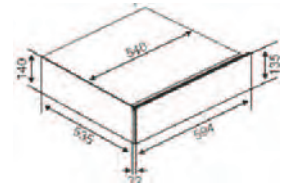

- stainless steelRDCT 140/1MIN



DOUBLE OVENS / PLAN RANGE



FDP 6109X BUILT-IN MULTI-FUNCTION DOUBLE OVEN

Plan styling > **Bottom oven:** Multi-function > LED display > "easy to clean" enamel interior > oven light > double glazed oven door > 1 shelf and 1 grill pan > 54 litre capacity > energy class A

Conventional Top oven > variable grill > oven light > double glazed door > 1 shelf and 1 grill pan > 39 litre capacity > energy class A

■ stainless steel FDP 6109X

■ black/stainless steel* FDP 6109NX

* stainless steel knobs and handles only

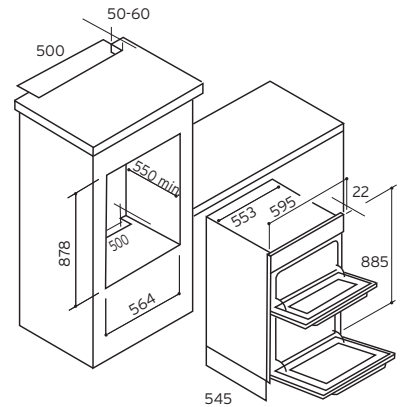

FDP 232/2 BUILT-IN FAN DOUBLE OVEN

Plan styling > **Bottom oven:** fan > electronic programmer > "easy to clean" enamel interior > oven light > double glazed oven door > 1 shelf and 1 grill pan > 54 litre capacity > energy class B > **Conventional Top oven** > variable grill > oven light > double glazed oven door > 39 litre capacity > energy class A

■ stainless steel FDP 232/2 X

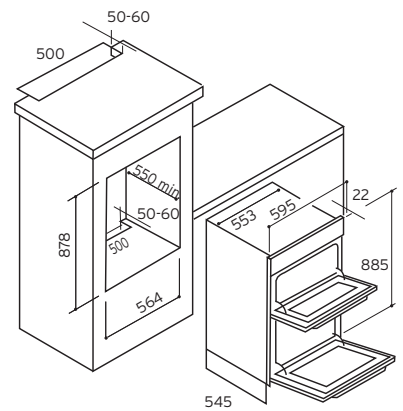

TCP 6107X BUILT-UNDER MULTI-FUNCTION DOUBLE OVEN

Plan styling > **Bottom oven:** Multi-function > LED display > "easy to clean" enamel interior > oven light > double glazed oven door > 1 shelf and 1 grill pan > 43 litre capacity > energy class A

Conventional Top oven > variable grill > oven light > double glazed door > 1 shelf and 1 grill pan > 39 litre capacity > energy class A

■ stainless steel TCP 6107X

■ black/stainless steel* TCP 6107NX

* stainless steel knobs and handles only

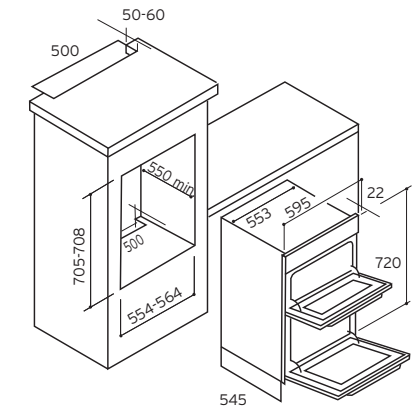

TCP 22/2 BUILT-UNDER FAN DOUBLE OVEN

Plan styling > **Bottom oven:** fan > electronic programmer > "easy to clean" enamel interior > oven light > double glazed oven door > 1 shelf and 1 grill pan > 43 litre capacity > energy class B > **Conventional Top oven** > variable grill > oven light > double glazed oven door > 1 shelf and 1 grill pan > 39 litre capacity > energy class A

■ stainless steel TCP 22/2 X

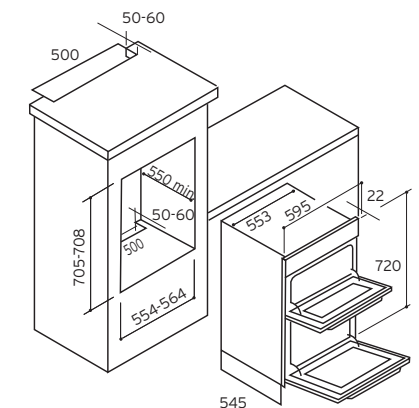

OVENS / GAS OVEN



OVG 505/3 GAS OVEN

Minute minder > traditional gas cooking > gas grill > fan cooled fascia and door > **electronic ignition for both oven and grill** > oven light > 2 shelves > 1 grill pan > double glazed door > 50 litre capacity energy class A

- stainless steelOVG 505/3X
- blackOVG 505/3N
- whiteOVG 505/3W

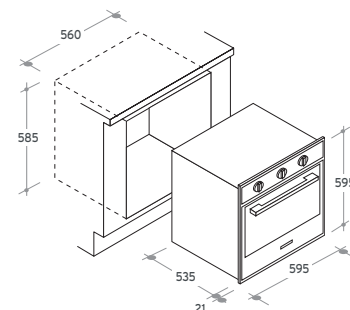

OVENS / CLASSIC OVEN



FCL 614 GH MULTI-FUNCTION OVEN

8 functions > variable grill > defrost function > conventional cooking > fan cooking > analogue clock > A class enamel - easy to clean oven interior > 2 shelves > 1 roasting tray/baking tray > integral fan cooling system > oven light > 65 litre capacity > energy class A+

- charcoalFCL 614GH

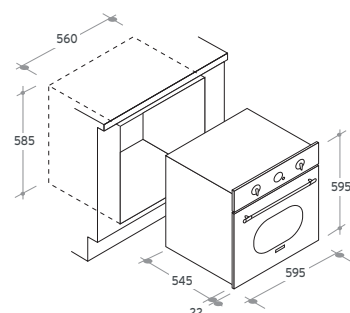

OVENS / COMBINATION OVEN, MICROWAVE AND GRILL



MIC 440TX

Fast, efficient microwave cooking, combined with the quality performance of a traditional fan oven, makes the Candy MIC440TX microwave a truly versatile appliance. With 8 cooking combinations to choose from and 5 power levels you can achieve perfect cooking results in a fraction of the time taken by a conventional oven.

High quality, durable stainless steel interiors are easy to clean so they are also more hygienic.

COMBINATION OVEN, MICROWAVE AND GRILL



MIC 440 TX
COMBINATION OVEN, MICROWAVE AND GRILL

Electronic touch control > **LED Clock/Programmer**
> **8 cooking combinations - conventional cooking, fan cooking, microwave cooking and grilling** > 13 automatic menus > 2 defrost functions > stainless steel cavity > 44 litre volume > 36cm diameter turntable > microwave power rating 900 W > grill power rating 1750 W > 5 power levels 150-900 W

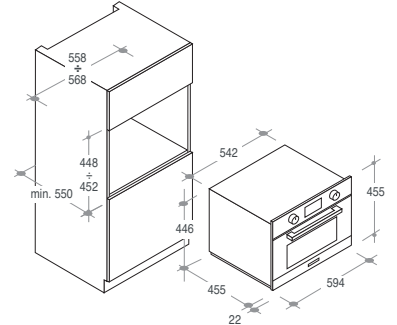

■ stainless steelMIC 440 TX

COMBINATION MICROWAVE OVEN AND GRILL



MICG 25 GDFN
COMBINATION MICROWAVE OVEN AND GRILL

5 power levels > **3 cooking combinations** > microwave plus grill > microwave only > grill only > **electronic controls** > 8 automatic cooking functions > stainless steel interior > 31.5cm diameter glass turntable > 25 litre capacity > microwave power rating 900 W > grill power rating 1000 W

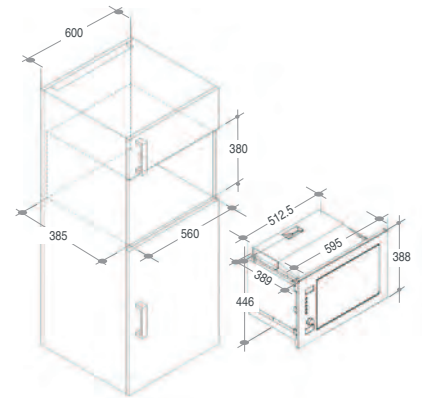

■ blackMIC25 GDFN

COMBINATION MICROWAVE OVEN AND GRILL



MIC 20 GDFX
COMBINATION MICROWAVE OVEN AND GRILL

5 power levels > **3 cooking combinations** > microwave plus grill > microwave only > grill only > **electronic controls** > 10 automatic cooking functions > defrost functions > stainless steel interior > 24.5cm diameter glass turntable > 20 litre capacity > microwave power rating 800 W > grill power rating 1000 W

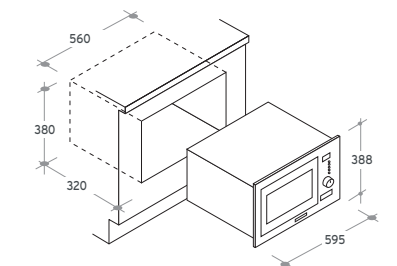

■ stainless steelMIC20 GDFX



■ RANGE COOKERS

Add a touch of luxury to your kitchen with a beautifully styled Candy range cooker.

Finished in high quality steel Candy range cookers offer excellent reliability and consistent cooking performance. The choice of home chefs, these dual fuel range cookers are available as single or twin cavities and come with a choice of 5 burner gas hob or 5 zone ceramic hob.

Electronic programmers

Designed to make life easy, clear LED displays and practical controls make the Candy range cooker simple to programme and use.

RANGE COOKERS / PLAN RANGE



CCV 9D52 X 90CM RANGE COOKER

Oven:

Multi-function main oven > grill > 6 functions > LED programmable timer > A class clean enamel - easy to clean oven interior > flat glass inner door > 51 litre capacity > energy class A > **Conventional second oven** > grill > 2 functions > 35 litre capacity > energy class A

Hob:

5 Ceramic zones > residual heat indicators > easy clean cooking surface > extendable centre zone

Additional features:

Storage compartment > adjustable feet

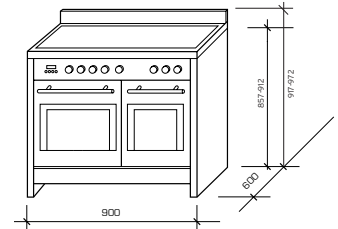

■ Stainless steelCCV 9D52 X



CCG 9D52 PX 90CM RANGE COOKER

Oven:

Multi-function main oven > grill > 6 functions > LED programmable timer > A class clean enamel - easy to clean oven interior > flat glass inner door > 51 litre capacity > energy class A > **Conventional second oven** > grill > 2 functions > 35 litre capacity > energy class A

Hob:

5 gas burners > one touch ignition > cast iron pan supports > 1 wok burner with stand 3.8kW > 1 rapid burner 3kW > 2 semi-rapid burners 1.75kW > 1 auxiliary burner 1kW > flame failure device

Additional features:

Storage compartment > adjustable feet

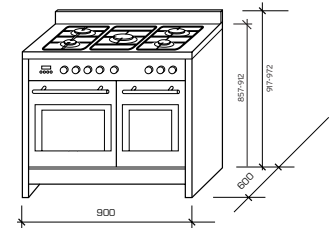

■ Stainless steelCCG 9D52 PX



CCG 9M52 PX 90CM RANGE COOKER

Oven:

Multi-function oven & grill > 8 functions > LED programmable timer > A class clean enamel - easy to clean oven interior > flat glass inner door > 108 litre capacity > energy class A

Hob:

5 gas burners > one touch ignition > cast iron pan supports > 1 wok burner with stand 3.8kW > 1 rapid burner 3kW > 2 semi-rapid burners 1.75kW > 1 auxiliary burner 1kW > flame failure device

Additional features:

Storage compartment > adjustable feet

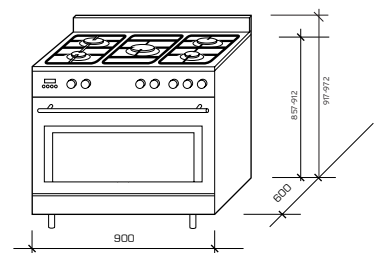

■ Stainless steelCCG 9M52 PX





Duo

■ **DUO**

Advanced technology with a practical design in one unique solution.

Introducing a multi-function oven and a 6 place setting dishwasher that fits perfectly into a 60cm space.



DUO 609 X
COMBINED OVEN AND DISHWASHER

Oven specification

Multi-function electric oven and grill > 39 litre capacity > oven light > touch controls > 5 functions > double glazed door > energy class A

Dishwasher specification

6 IEC place settings > 6 programmes > 5 wash temperatures > 32 minute rapid programme > **Eco bio 45°C programme** > delicates programme > water consumption 9 litres > energy efficiency class A

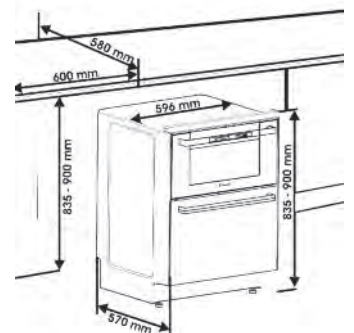

■ stainless steelDUO 609 X



Electric multi-function oven



Ceramic hob



6 place-setting dishwasher

■ **TRIO** - The big solution for small kitchens - combined oven, hob and dishwasher in a 60cm space.

Introducing a combination oven, hob and dishwasher that makes the most of limited space. With smart technology, smart design and unrivalled flexibility, the Trio offers a whole new dimension in kitchen design.

COMBINED OVENS / TRIO RANGE



TRIO 9503 X
COMBINED OVEN, CERAMIC HOB AND
DISHWASHER

Ceramic Hob Specification: 4 hi-light zones >
Oven Specification: multi-function electric oven
and grill > oven interior light > 39 litre oven
capacity > end of cooking timer > double glazed
door > energy class A > **Dishwasher
Specification:** 6 IEC place settings > 5
programmes > 32 minute rapid programme
> Anti-overflow device > Water consumption 8
litres > energy efficiency class A > wash
efficiency class A > drying efficiency class A >
dimensions > height mm 865-900 (adjustable
feet) > width mm 596 > depth mm 600



**Optional matching stainless steel 60cm
splashback PM60X and 60cm chimney hood
CCT685X**

■ stainless steelTRIO 9503 X



■ HOBBS

CVG 75SQPN

A sleek, stylish hob design, combined with the total controllability of gas means that the Candy CVG 75 SQPN gas on glass model will be more than just an elegant addition to your kitchen. Easy to use controls direct a precise, regulated flame to each of the burners, whilst the high intensity quadruple ring burner is perfect for Wok style cooking, so even the most demanding of cooks will be impressed by its practical professional design.

HOBS

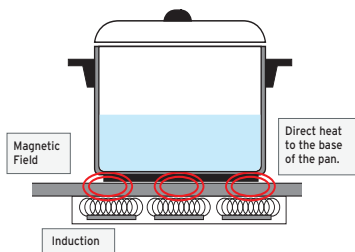

A sleekly designed and solidly built range of 60cm and 75cm hobs include gas hobs with practical features that include quadruple ring burners and state of the art ceramic models that combine touch control with high light rapid response sprinter technology.

Induction Hob Efficiency

Induction hobs utilise Electromagnetic technology so that when a pan is placed on the induction heating zone it completes a magnetic circuit below the hob surface, causing only the contents of the pan to heat. It heats up a half litre of water in less than half the time and the surface temperature only reaches 81°C compared to a normal electric hob which can reach up to 410°C. Induction hobs are faster, more energy efficient and more controllable. It is also the safest type of hob, particularly if there are children present, as it will only heat up when the saucepan is placed on the hob.

Candy Flexi Hob

The Candy Flexi Induction hob is a controllable, safe and efficient way to cook. With futuristic touch control design the CFID 36 model has an extra large cooking area that offers flexible, zoneless cooking plus two conventional zones. The introduction of this new zoneless technology means that lots of different sized pans can be placed anywhere inside the large cooking areas and moved around with ease.

Low Absorption Induction Hob

Using less than half the energy of normal induction hobs, the Candy CI 640 CBA low absorption hob comes complete with a 13 amp plug fitted, reducing the need for costly installation.



FLAME FAILURE DEVICE

In the event of the flame being extinguished accidentally a thermocouple device will automatically cut-off the gas supply.



AUTOMATIC IGNITION

Central control panels make it easier to reach and use the control knobs. Electronic ignition control is integrated in the control knobs, to allow single handed operation; the raised and inclined panel avoids overheating.

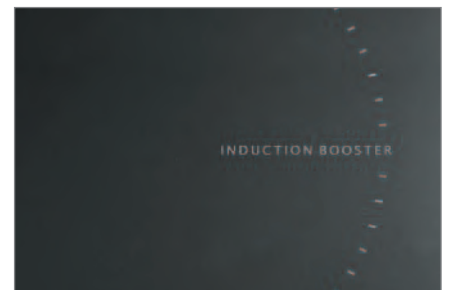

INDUCTION HOBBS

Induction hobs operate at 90% efficiency and are more environmentally friendly than any other hob, consuming half the electricity of the next most efficient hob and one third the energy of an electric sealed plate hob.

HOBS 75CM / GAS ON GLASS



CVG 75 SQPN 75CM PLAN HOB

5 gas burners > **one touch ignition** > 5 enamelled pan supports > flame failure device > 1 quadruple ring burner 3.5 kW > 2 rapid burners 2.5 kW > 1 semi-rapid burners 1.75 kW > 1 auxiliary burner 1kW

Also available in 60cm - CVG 64 SPN

4 gas burners > 1 rapid burner 2.5kW > 2 semi-rapid burners 1.75 kW > 1 auxiliary burner 1.0 kW > 4 enamelled pan supports

-  blackCVG 64 SPN
-  blackCVG 75 SQPN

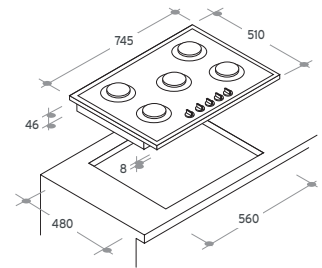

HOBS 75CM / PLAN RANGE



CPG 75 SQPX 75CM GAS HOB

5 gas burners > **one touch ignition** > enamelled pan supports > 1 quadruple ring burner 4 kW > 2 rapid burners 2.5 kW > 1 semi-rapid burner 1.75 kW > 1 auxiliary burner 1 kW > single piece hob plate > flame failure device

CPG 75 SQGX available with cast iron pan supports (not shown)

-  stainless steelCPG 75 SQPX
-  stainless steelCPG 75 SQGX

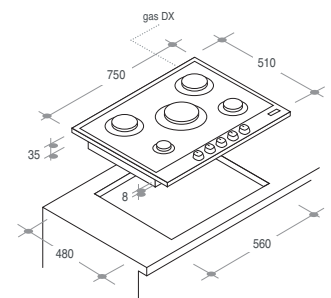

HOBS 75CM / PLAN RANGE



CPG 74 SQGX 75CM PLAN HOB

4 gas burners > **one touch ignition** > cast iron pan supports > flame failure device > 1 quadruple ring burner 4kW > 1 rapid burner 2.5kW > 1 semi-rapid burner 1.75kW > 1 auxiliary burner 1kW

-  stainless steelCPG 74 SQGX

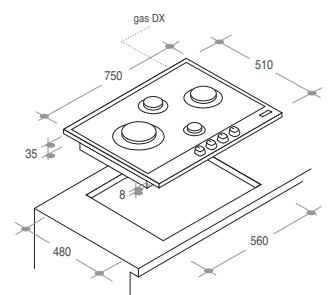

GAS HOBS / CLASSIC RANGE



CPGC 64 SQPGH
60CM GAS HOB

4 gas burners > **one touch ignition** > 1 quadruple burner 4.0 kW > 1 rapid burner 2.7 kW > 1 semi-rapid burner 1.7 kW > 1 auxiliary burner 1kW > flame failure device > enamelled pan supports

■ charcoalCPGC 64 SQPGH

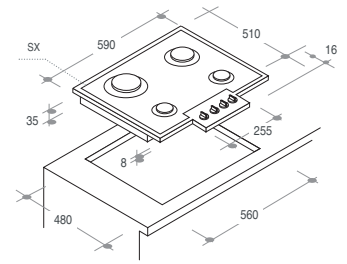

HOBS 60CM / PLAN RANGE



CPG 64SP
60CM GAS HOB

4 gas burners > **one touch ignition** > flame failure device > 1 rapid burner 2.5 kW > 2 semi-rapid burners 1.75 kW > 1 auxiliary burner 1kW > 2 enamelled pan supports > single cast hob plate

■ stainless steelCPG 64SPX
■ blackCPG 64SPN
■ whiteCPG 64SPB

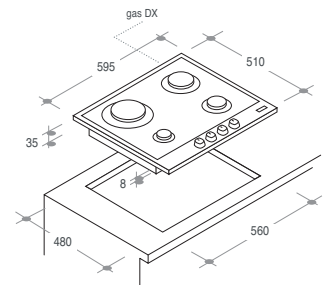

HOBS 60CM / GAS HOBS



CLG 64 SP
GAS HOB

4 gas burners > **one touch ignition** > flame failure device > 1 rapid burner 2.7 kW > 2 semi-rapid burners 1.7 kW > 1 auxiliary burner 1.0 kW > 2 enamelled pan supports

■ stainless steelCLG 64 SPX
■ blackCLG 64 SPN
■ whiteCLG 64 SPB
■ stainless steelCLG 64 SGX with cast iron pan supports

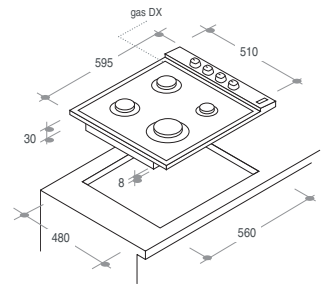

HOBS 60CM / ELECTRIC HOBS



PLE 64
60CM ELECTRIC HOB

High precision controls > 4 solid electric hot plates, include 2 rapid hot plates > 2 hotplates Ø 180 mm 2.0 kW > 2 hotplates Ø 145 mm 1.5 kW > single-cast hob plate

■ stainless steelPLE 64 X
■ blackPLE 64 N
■ whitePLE 64 W

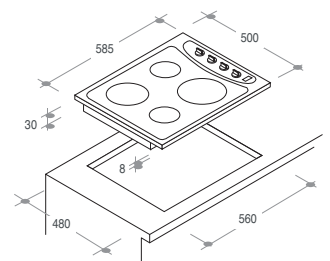

HOBS / INDUCTION HOBS



CFID 36 60CM FLEXI INDUCTION HOB

Digital touch controls > **4 induction zones** > including flexible cooking zone > 2 Induction zones 200mm 1.5/2kW > 2 Induction zones 200mm 2.3kW which can be 1 Full Flexi zone 190 x 400mm 3/3.6kW > heat-on warning lights > child safety lock

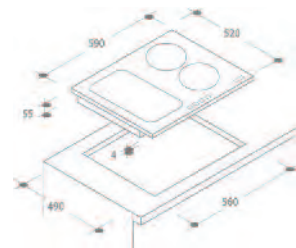

■ blackCFID 36



CI 640 C 60CM INDUCTION HOB

Digital touch controls > timer on each zone > **4 induction zones** > 1 zone Ø 210mm 2kW > 1 zone Ø 180mm 2kW > 2 zones Ø 180mm 1.5kW > child safety lock

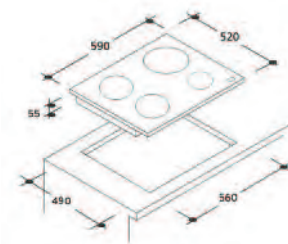

■ blackCI 640 C



CI 640 CBA 60CM INDUCTION HOB - LOW ABSORPTION

Digital touch controls > timer on each zone > **4 induction zones** > 1 zone Ø 210mm 2kw > 1 zone Ø 180mm 2kw > 2 zones Ø 180mm 1.5kw > easy to clean cooking surface > child safety lock > fitted with a 13 amp plug

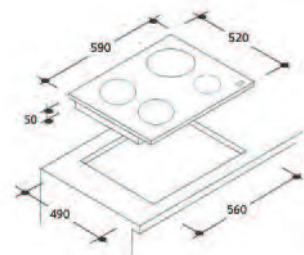

■ black (no trim)CI 640 CBA

HOBS / HI-LIGHT SPRINTER CERAMIC



CH 742 75CM TOUCH CONTROL HI-LIGHT CERAMIC HOB

Digital touch controls > end of cooking timer on a cooking area of your choice > **4 hi-light rapid sprinter cooking zones** > 1 hi-light zone 190mm 1.8kW > 1 hi-light extendable double zone 130/220mm 0.75/1.45kW > 1 hi-light extendable double zone 180/275mm 0.90 + 1.5kW > 1 hi-light zone 155mm 1.2kW > easy to clean cooking surface > child safety lock > bevelled front edge

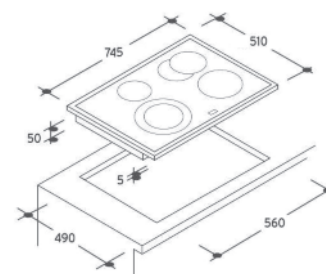

■ black (bevelled front edge)CH742 B



CH 642 60CM TOUCH CONTROL HI-LIGHT CERAMIC HOB

Digital touch controls > end of cooking timer on a cooking area of your choice > easy to clean cooking surface > **4 hi-light rapid sprinter cooking zones** > 1 hi-light zone Ø 155mm 1.2kW > 1 hi-light double zone Ø 130/220mm 1.45 + 2.2kW > 2 hi-light zones Ø 190mm 1.8kW > child safety lock

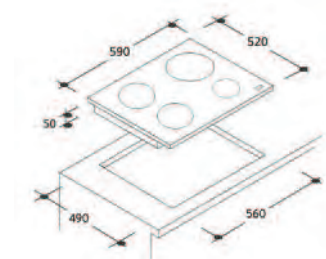

■ stainless steel (front trim only)CH 642X

■ black (bevelled front edge)CH 642B

HOBS / HI-LIGHT CERAMIC



CH 64M 60CM HI-LIGHT CERAMIC HOB

Traditional high precision control knobs > 4 heat-on warning lights > easy to clean surface > **4 hi-light rapid sprinter cooking zones** > 1 hi-Light zone Ø 220mm 2.3 kW > 1 hi-light zone Ø 190mm 1.8 kW > 2 hi-light zones Ø 155mm 1.2 kW

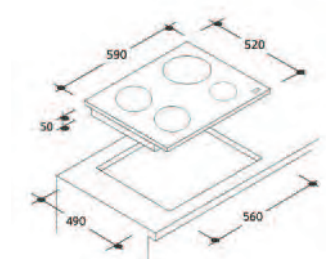

■ stainless steel (front trim only) CH 64MX

■ black (bevelled front edge)CH 64MB

HOBS / DOMINO HOBS



CDG 31/1SPX GAS HOB

1 gas wok burner 3.5kW > flame failure device > enamel pan support > one touch ignition

■ stainless steel CDG 31/1SPX

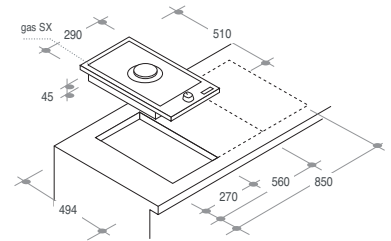

CDG 32/1SPX GAS HOB

2 gas burners > flame failure device > 1 ultra rapid burner 3.0kW > 1 auxiliary burner 1.0kW > one touch ignition > enamel pan support

■ stainless steel CDG 32/1SPX

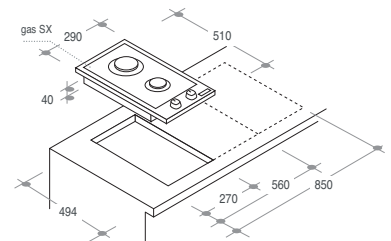

CDH 32/1X CERAMIC HOB

2 cooking zones > 1 zone 180mm 1.7kW > 1 zone 145mm 1.2kW > easy to clean surface

■ stainless steel CDH 32/1X

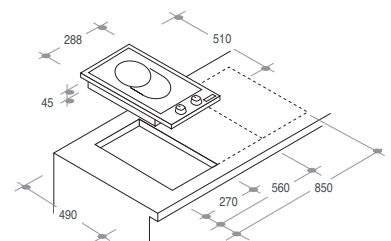

CDI 32/1B INDUCTION HOB

Digital touch controls > 2 heat-on warning lights > easy to clean surface > 2 induction zones > 1 zone 160mm 1.4kW > 1 zone 200mm 2.3-3kW > cooking timer

Also available is a Ceramic Hob - CDH 32/1C with digital touch control > 2 cooking zones > 1 zone 180mm 1.7kW > 1 zone 145mm 1.2kW > cooking timer > child safety lock

■ black (bevelled edge) CDI 32/1B

■ black (bevelled edge) CDH 32/1C

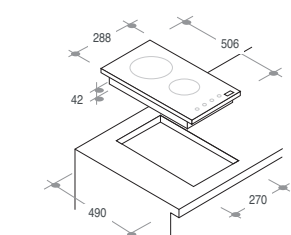

HOBS / DOMINO HOBS



CDE 32/1X ELECTRIC HOB

1 hotplate 180mm 1.5kW > 1 hotplate 145mm 1.5kW >
1 rapid zone > high precision control knobs

■ stainless steel CDE 32/1X

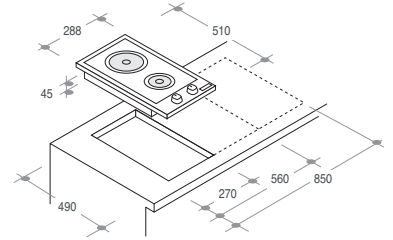

CDVG 30/1X GRIDDLE

Residual heat indicator > cooking zone 250x400mm
1.5kW > high precision control knob

■ stainless steelCDVG 30/1X

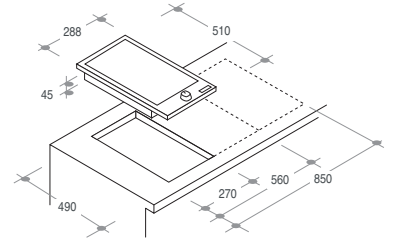

CDB 30/1X BBQ

Cooking area 220x320mm 2.4kW > enamel support
> adjustable temperature control

■ stainless steel CDB 30/1X

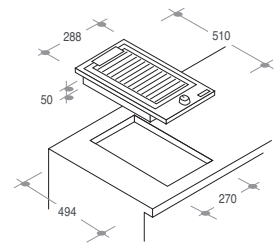

CDF 30/1X FRYER

Deep fat fryer 2.3kW > cooking basket > lid >
adjustable temperature control

■ stainless steel CDF 30/1X

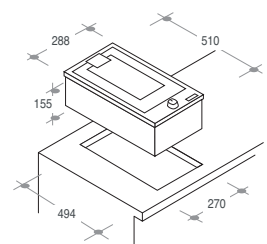



HOODS

Candy's hoods whether chimney or decor style, in futuristic or more traditional design, incorporate the very latest electronic touch control technology. They offer great performance, high extraction rates, low noise levels and bright halogen hob and work surface illumination.



HALOGEN LIGHTS

Illuminate the hob with bright halogen lights - improving the whole cooking experience.



DECOR HOODS

Candy combines glass and stainless steel to enhance the overall impact of your kitchen.



EXTRACTION RATES

Candy hoods are amongst the quietest and most efficient available capable of removing most cooking odours effortlessly.

DECOR HOODS / ISLAND TUBE HOOD



CIDT 61 X
40CM ISLAND TUBE HOOD

Motor 250 W > Extraction flow rate 520 m³/h > 4 speeds operated by electronic touch controls > 2 halogen lights > perimeter filtration > filter saturation indicator > timer > clean air function > charcoal filter optional extra

 stainless steelCIDT 61 X

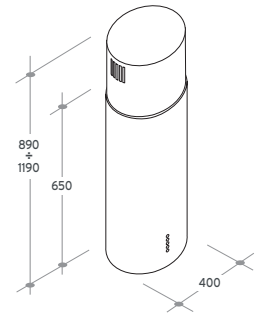

DECOR HOODS / ISLAND CUBE HOOD



CIDC 61 X
70CM ISLAND TUBE HOOD

Motor 250 W > extraction flow rate 710 m³/h > electronic touch controls > 4 halogen lights > perimeter filtration > filter saturation indicator > timer > clean air function > charcoal filter optional extra

 stainless steelCIDC 61 X

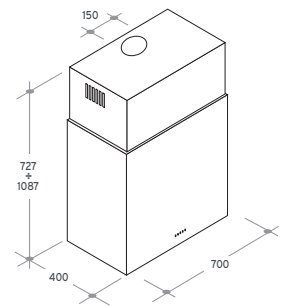

DECOR HOODS / TUBE HOOD



CDT 61 X
40CM TUBE DECOR HOOD

Motor 250 W > Extraction flow rate 520 m³/h > 4 speeds operated by electronic touch controls > 2 halogen lights > filter saturation indicator > perimeter filtration > timer > Convertible: extraction or recirculation > Charcoal filter optional extra

 stainless steelCDT 61 X

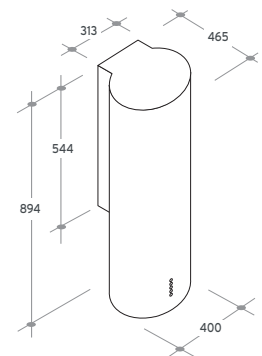

DECOR HOODS / CUBE HOOD



CDC 61 X
60CM CUBE DECOR HOOD

Motor 250 W > extraction flow rate 710 m³/h > 3 speeds operated by push button controls > 2 halogen lights > perimeter filtration > Convertible: extraction or recirculation > Charcoal filter optional extra

 stainless steelCDC 61X

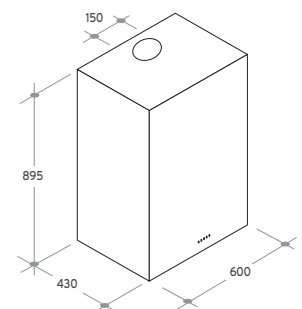

DECOR HOODS / PLAN RANGE

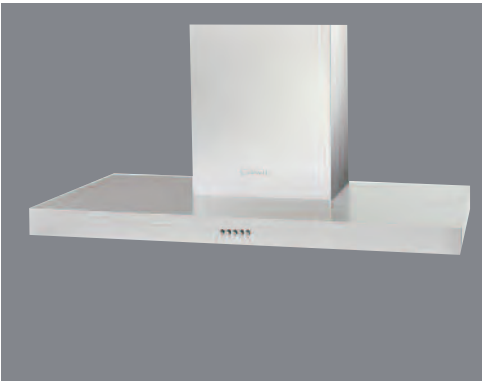

CMB 950
90CM HOOD

Turbo motor 100 W > extraction flow rate 550 m³/h > 3 speeds operated by push button controls > 2 LED lights > convertible: extraction or recirculation > washable metal grease filter > charcoal filters included

■ stainless steelCMB 950 X

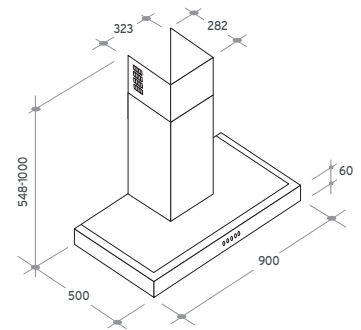

DECOR HOODS / PLAN RANGE

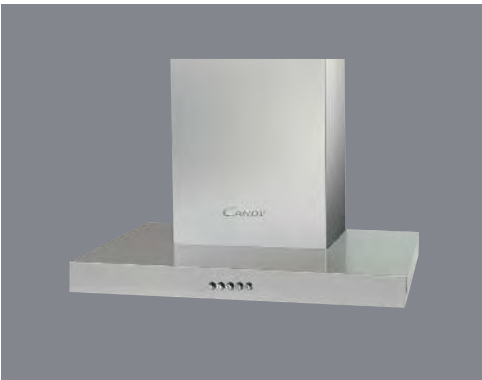

CMB 650 X
60CM HOOD

Turbo motor 100 W > extraction flow rate 550 m³/h > 3 speeds operated by push button controls > 2 LED lights > convertible: extraction or recirculation > washable metal grease filter > charcoal filters included

■ stainless steelCMB 650 X

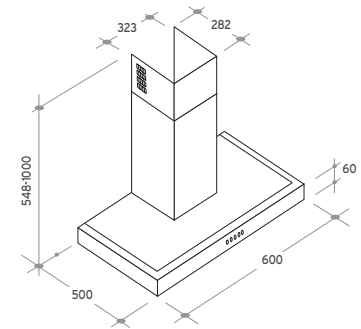

DECOR HOODS



CVM 970 LX
90CM DECOR HOOD

Turbo motor 213 W > extraction flow rate 750 m³/h > 3 speeds operated by touch controls > 2 LED lights > convertible: extraction or recirculation > washable metal grease filter > charcoal filters included

■ stainless steelCVM 970 LX
Also available CVM1970LX Island Hood

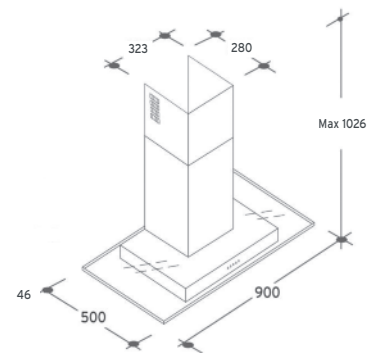

DECOR HOODS



CRD 93 X
90CM ROUND DECOR HOOD

Turbo motor 230 W > extraction flow rate 550 m³/h > 3 speeds operated by push button controls > 2 x 28W halogen lights > timer > clean air function > convertible: extraction or recirculation > washable metal grease filter > charcoal filters included

■ stainless steelCRD 93 X

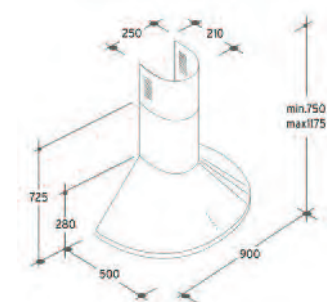

DECOR HOODS



CCR 616/1X 60CM ROUND DECOR HOOD

Turbo motor 150 W > extraction flow rate 450 m³/h
> 3 speeds operated by slider controls > 2 x 28W halogen lights > convertible: extraction or recirculation > washable metal grease filter > charcoal filters included

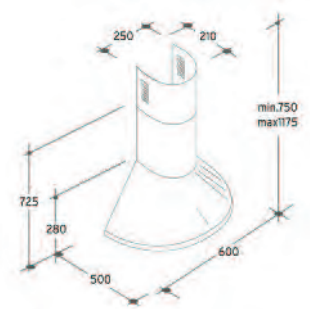

■ stainless steelCCR 616/1X

DECOR HOODS



CGM 91 / CGM 61 90 & 60CM GLASS DECOR HOOD

Turbo motor 100 W > extraction flow rate 550 m³/h
> 3 speeds operated by push button control > tempered safety glass > 2 LED lights > convertible: extraction or recirculation > washable metal grease filter > charcoal filters included

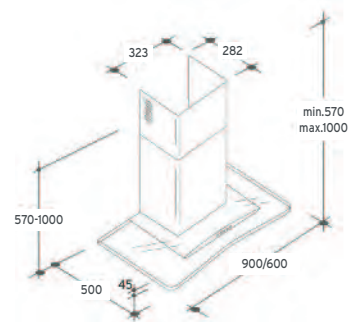

Also available in 60cm - CGM 61X

■ stainless steelCGM 91 X
■ stainless steelCGM 61 X

CHIMNEY HOODS



CCT 985 / CCT 685 90 & 60CM CHIMNEY HOODS

Turbo motor 250W > extraction flow rate 850m³/h
> 3 speeds operated by push button controls > 2 x 20W halogen lights > convertible: extraction or recirculation > washable metal grease filters > charcoal filters included

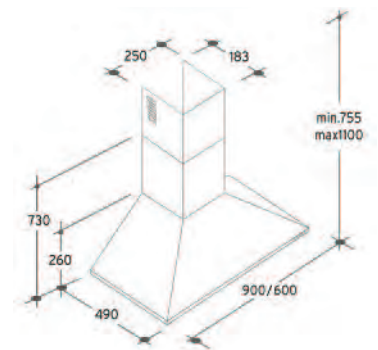

Also available in 60cm - CCT 685

■ stainless steelCCT 985 X
■ stainless steelCCT 685 X
■ blackCCT 685 N
■ whiteCCT 685 W

INTEGRATED HOODS



CBP 612/1 60CM WIDE

Motor 110W > extraction flow rate 230m³/h > 3 speeds > 2 x 28W halogen bulbs > convertible: extraction or recirculating > acrylic filter / charcoal filter

- greyCBP 612/1 GR
- blackCBP 612/1 N
- whiteCBP 612/1 W

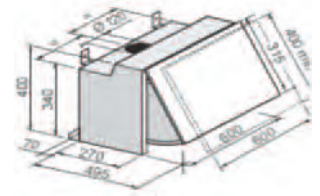

CANOPY HOODS



CBG 620 60CM WIDE

Motor 100W > extraction flow rate 170m³/h > 3 speeds operated by slider > 2 x 28W halogen bulbs > convertible: extraction or recirculation > acrylic filter > charcoal filter included

- silverCBG 620 S
- blackCBG 620 N
- whiteCBG 620 W

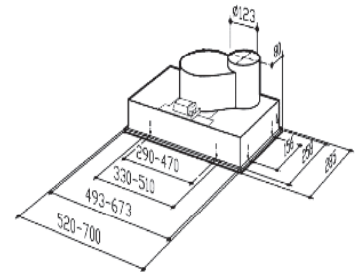

CONVENTIONAL HOODS



CFT 610/2 60CM WIDE

Motor 120W > extraction flow rate 180m³/h > 3 speeds > slider controls > 2 x 28W halogen bulbs > convertible extraction or recirculation > acrylic filter > charcoal filter included

- silverCFT 610/2S
- blackCFT 610/2N
- whiteCFT 610/2W

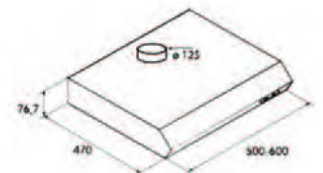



■ DISHWASHERS & HOME LAUNDRY

Candy's integrated laundry and dishwashers are an ingenious blend of styling and technology, offering an outstanding performance, they are extremely efficient and are exceedingly quiet.

Home Laundry

Large Load Capacity - The Candy CDB 854 integrated washer dryer is capable of handling a 8kg wash & 5kg dry load, perfect for busy families.



Dishwashers

The Eco CDIM 3653 dishwasher uses just 10 litres to wash a full load. The water is filtered and recirculated over 7,800 times to ensure an A rated wash performance, whilst maximising water usage.



This dishwasher features a combination of 3 baskets and 15 place settings and provides additional valuable loading space in the top basket. The top basket is perfect for small coffee cups, saucers, side plates and cooking utensils.



All Candy dishwashers are rated A+ for energy efficiency and A for washing and drying performance.



TIME SAVING WASHING MACHINE

The CDB 854 is perfect for busy people - the rapid 59 minute programme means that you can wash and dry 3 garments in under an hour, perfect for those forgotten items.



SELF-CLEANING FILTER

Self-cleaning filter: the microfilter in Candy dishwashers keeps water constantly clean for maximum wash efficiency and an end of cycle jet of water expels any impurities trapped in the filter.

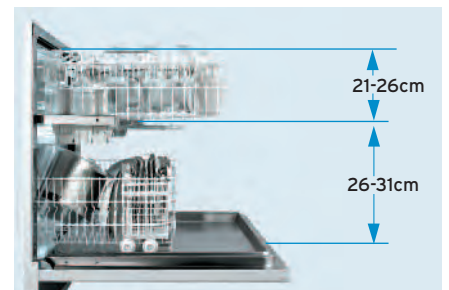

ADJUSTABLE BASKETS

Adjustable Baskets: the upper basket in Candy dishwashers are height adjustable and have a range of between 21 and 26 cm, giving the lower basket a range of between 26 and 31 cm.

FULLY INTEGRATED DISHWASHERS



CDIM 3653 FULLY INTEGRATED DISHWASHER

15 place settings > 3 baskets > Maxi plate system
> 6 programmes > 4 wash temperatures > 32
minute rapid programme > programme selection by
button > adjustable upper basket > front access
levelling facility > 3-6-9 hrs start delay > balanced
door > self-cleaning micro filter > energy efficiency
A+ > wash efficiency A > drying efficiency A

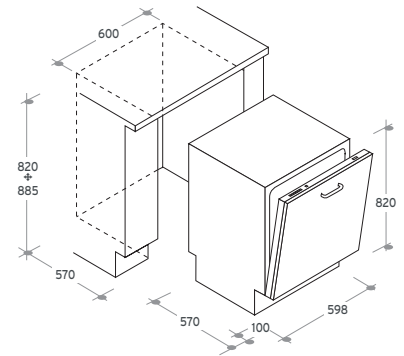

CDI 1012/4-80 FULLY INTEGRATED DISHWASHER

12 place settings > 5 programmes > 4 wash
temperatures > 32 minute rapid programme >
water softener settings > balanced door >
adjustable upper basket > self-cleaning micro filter
> energy efficiency class A+ > wash efficiency class
A > drying efficiency class A

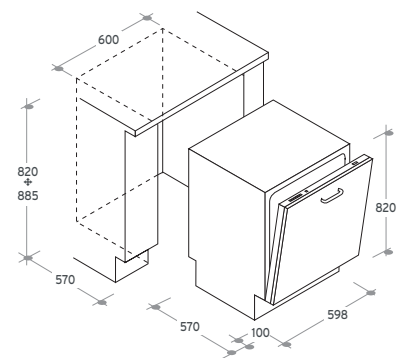

INTEGRATED DISHWASHER



CDS 420 INTEGRATED DISHWASHER

12 place settings > **7 programmes** > **5 wash temperatures** > **32 minute rapid programme** > adjustable upper basket > self-cleaning micro filter > half load button > balanced door > salt indicator light > energy efficiency class A+ > wash efficiency class A > drying efficiency class A

- stainless steel fasciaCDS 420X
- black fasciaCDS 420N

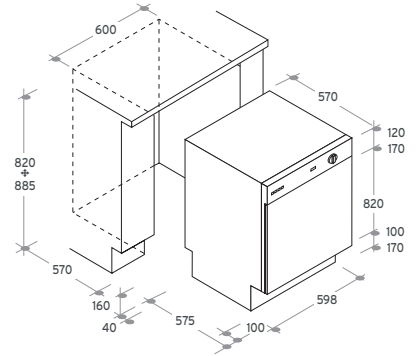

FULLY INTEGRATED SLIMLINE DISHWASHER



CDI 4545/E 45CM FULLY INTEGRATED DISHWASHER

9 IEC place settings > LED digital display > **7 programmes** > **4 wash temperatures** > adjustable upper basket > 24 hour start delay > programme selection button > intensive wash programme > rapid programme > energy efficiency class A+ > washing efficiency class A > drying efficiency class A

- whiteCDI 4545E

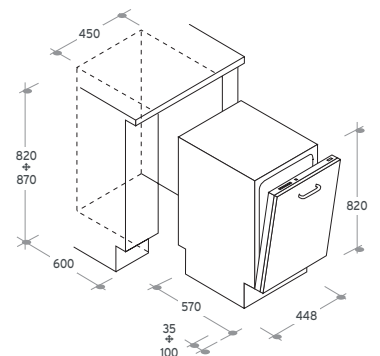

FULLY INTEGRATED WASHER DRYER



CDB 854DN FULLY INTEGRATED WASHER DRYER

1400rpm > **8kg wash and 5kg drying capacity** > stainless steel drum assembly > 12 wash programmes > **fuzzy logic** > KG mode > LED display > rapid 14, 30 and 44 minute programmes > start delay (up to 23 hours) > digital countdown indicator > mixed wash programme > delicate/hand wash programme > stain buster button > automatic variable capacity > **3 drying programmes** > high dry button > cold fill only > adjustable feet > energy efficiency class B

whiteCDB 854DN

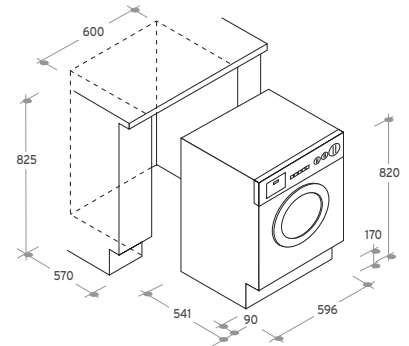

CDB 754 ND/1 FULLY INTEGRATED WASHER DRYER

1400 r.p.m. > **7kg wash and 5kg drying capacity** > stainless steel drum assembly > 12 wash programmes > **Fuzzy Logic** > start delay (up to 23 hours) > LED display > digital countdown indicator > rapid 14, 30 & 44 minute programme > half load option > mixed wash programme > delicates/ hand wash programme > stain buster button > allergy care button > automatic variable capacity > **2 dry programmes** > high dry button > cold fill only > adjustable feet > energy efficiency class A

whiteCDB 754 ND/1

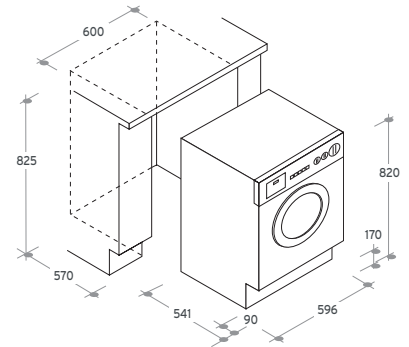

CDB 264N FULLY INTEGRATED WASHER DRYER

1200 r.p.m. > 6kg wash and 4kg drying capacity > stainless steel drum assembly > 12 wash programmes > 30 minute wash programme > 2 drying programmes > fuzzy logic > start delay (up to 9 hours) > automatic variable capacity > variable thermostat > stain buster button > high dry button > drying time selection control > oval tub > crease free final cool tumble > cold fill only > fast iron button > cupboard dry ironing > adjustable feet > energy efficiency class B

whiteCDB 264N

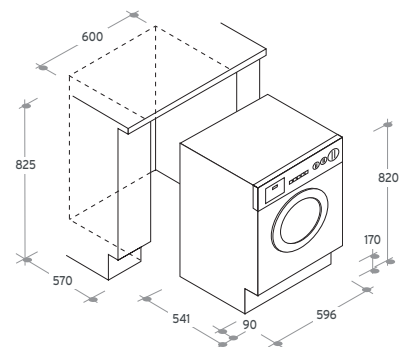

FULLY INTEGRATED WASHING MACHINE



CWB 814 DN1 FULLY INTEGRATED WASHING MACHINE

1400rpm > **8kg wash capacity** > **stainless steel drum assembly** > 12 wash programmes > KG mode > LED display > rapid 14, 30 and 44 minute programmes > start delay (up to 23 hours) > digital countdown indicator > pre-wash programme > mixed wash programme > delicate/hand wash programme > stain vanish button > automatic variable capacity > adjustable feet > energy efficiency class A+

whiteCWB 814 DN1

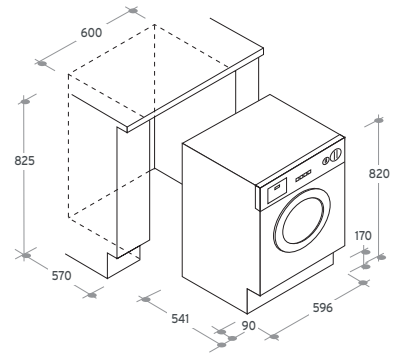

CWB 714 DN1 FULLY INTEGRATED WASHING MACHINE

1400 r.p.m. > **7kg wash capacity** > **stainless steel drum assembly** > 13 programmes > rapid 14, 30 & 44 minute programmes > LED display > digital countdown indicator > start delay (up to 23 hours) > half load option > fuzzy logic > pre-wash programmes > mixed wash programme > delicate/hand wash programme > stain buster button > easy iron button > allergy care button > automatic variable capacity > cold fill only > adjustable feet > energy efficiency class A+

whiteCWB 714 DN1

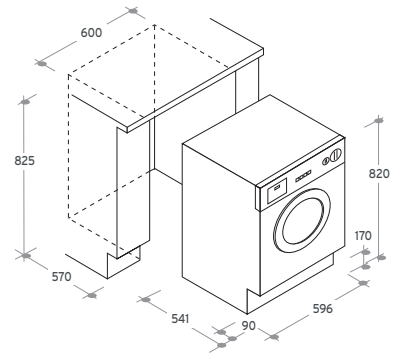

CWB 1462 DN1 FULLY INTEGRATED WASHING MACHINE

1400 r.p.m. > **6kg wash capacity** > **stainless steel drum assembly** > 15 programmes > 30 minute wash programme > start delay (up to 9 hours) > fuzzy logic > pre-wash programme > half load option > automatic variable capacity > variable thermostat > variable spin speed from 0-1400r.p.m. > extra rinse button > allergy care button > easy iron button > oval tub > cold fill only > adjustable feet > energy efficiency class A+

whiteCWB 1462 DN1

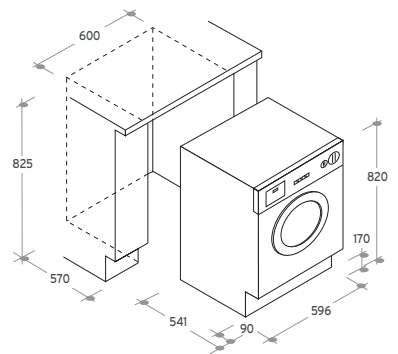



REFRIGERATION

From modern compact fridges to large capacity fridge freezers our integrated appliances will co-ordinate with any kitchen setting. Whether it's frost free technology or simply an extra large integrated fridge you require we have a range of innovative cooling products to suit every requirement.

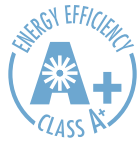

Energy Efficiency

All Candy refrigeration are rated A+ for energy efficiency.



Candy Frost Free Fridge Freezers prevent frost formation in the freezer section, which means never having to defrost the freezer.



MAINTAINS CONSTANT TEMPERATURE

Candy's 'turbo cooling' feature ensures even temperature distribution throughout the refrigerator.



VERSATILE STORAGE SOLUTIONS

Adjustable shelving allows large or bulky items to be stored safely.



GLASS SHELVING

Easy care glass shelving ensures maximum hygiene.

FULLY INTEGRATED FRIDGE FREEZER / REFRIGERATION



CXSE 7204

FROST FREE SIDE BY SIDE FRIDGE FREEZER

Freezer rating. *** > total net capacity 537 litres (19.0 cu.ft) > net refrigerator capacity 345 litres (12.1 cu.ft) > net freezer capacity 192 litres (6.9 cu.ft) > electronic control > energy efficiency class A+ > climate class SN-ST > dimensions H X W X D 1757 x 890 x 681

Refrigerator

4 adjustable glass shelves > 5 door shelves > 2 pull out refrigerator drawers with humidity control

Freezer

3 glass shelves > 5 door shelves > 3 transparent freezer drawers



silverCXSE 7204

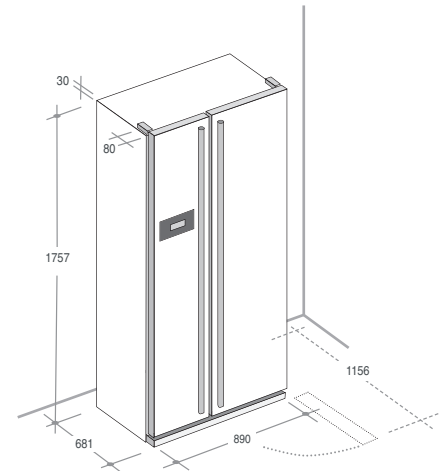

CKBC 3150E UK

FRIDGE FREEZER

Freezer rating. *** > total gross capacity 281 litres (9.9 cu.ft) > net refrigerator 203 litres (7.2 cu.ft) > net freezer capacity 60 litres (2.1 cu.ft) > 24hr freezer capacity 3kg > climate class ST > energy efficiency class A+ > glass shelves > automatic defrosting (fridge) > reversible doors > **housing dimensions** > height mm 1772 ÷ 1776 > width mm 560 > depth mm 550

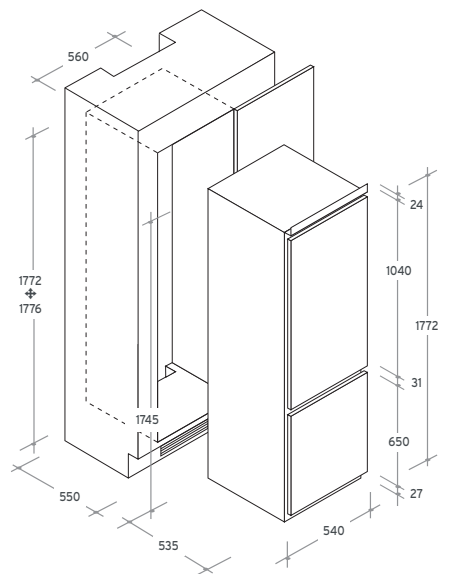

FULLY INTEGRATED FRIDGE FREEZER / REFRIGERATION



CFBC 3050 EK FRIDGE FREEZER

Freezer rating. **** > total gross capacity 263 litres (9.3 cu.ft) > net refrigerator capacity 156 litres (5.5 cu.ft) > net freezer capacity 86 litres (3.0 cu.ft) > 24 hr freezing capacity 4 kg > climate class ST > energy efficiency class A+ > glass shelves > automatic defrosting (fridge) > reversible doors > **housing dimensions** > height mm 1772-1776 > width mm 560 > depth mm 550

Also available as a Frost Free model:-

CFBF 3050 EK FROST FREE FRIDGE FREEZER

Freezer rating. **** > Frost Free > total gross capacity 255 litres (9.0 cu.ft) > net refrigerator capacity 156 litres (5.5 cu.ft) > net freezer capacity 78 litres (2.7 cu.ft) > 24 hr freezing capacity 4 kg > climate class SN/ST > energy efficiency class A+ > glass shelves > reversible doors > **housing dimensions** > height mm 1772-1776 > width mm 560 > depth mm 550

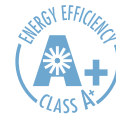
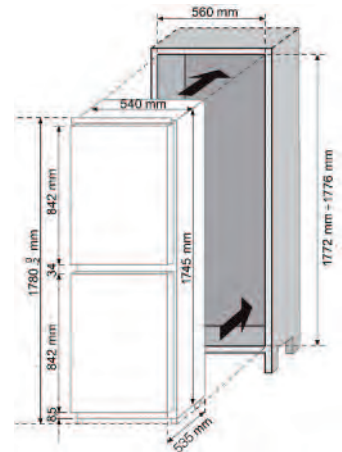
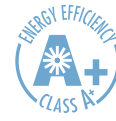

FULLY INTEGRATED FRIDGE / REFRIGERATION



CIO 225 E REFRIGERATOR

Freezer rating. **** > total gross capacity 205 litres (7.24 cu.ft) > net refrigerator capacity 175 litres (6.2 cu.ft) > net freezer capacity 17 litres (0.6 cu.ft) > 24hr freezing capacity 2 Kg > climate class N/ST > energy efficiency class A+ > automatic defrosting > glass shelves > reversible door > **housing dimensions** > height mm 1225 ÷ 1227 > width mm 560 > depth mm 550

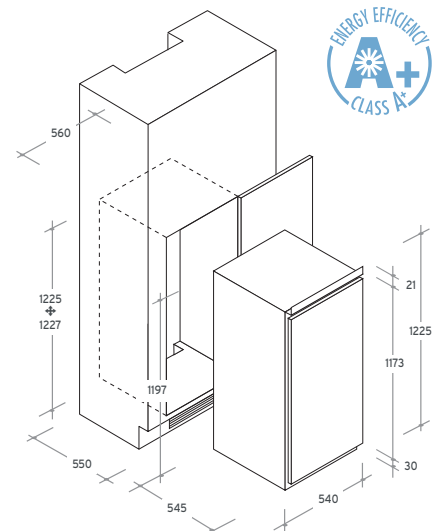

FULLY INTEGRATED LARDER FRIDGE / REFRIGERATION



CFLO 3550E BUILT-IN TALL LARDER

Total gross capacity 319 litres (11.27 cu.ft) > net refrigerator capacity 316 litres (11.17 cu.ft) > climate class ST > energy efficiency class A+ > glass shelves > LED Light > reversible door > **housing dimensions** > height mm 1772 - 1776 > width mm 560 > depth mm 550

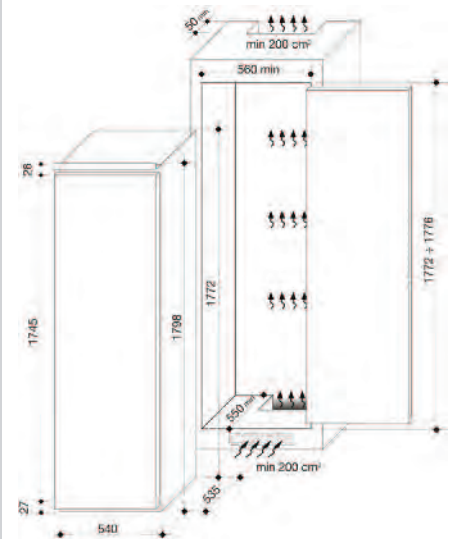
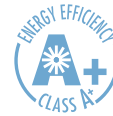

FULLY INTEGRATED FREEZER / REFRIGERATION



CFFO 3550E BUILT-IN TALL FREEZER

Total gross capacity 228 litres (8.06 cu.ft) > freezer net capacity 217 litres (7.67 cu.ft) > 24 hr freezing capacity 10.5 kg > climate class ST > energy efficiency class A+ > reversible door > manual defrosting > on/off - green light > fast freezer - yellow light > freezer warning - red light > **housing dimensions** > height mm 1772 - 1776 > width mm 560 > depth mm 550

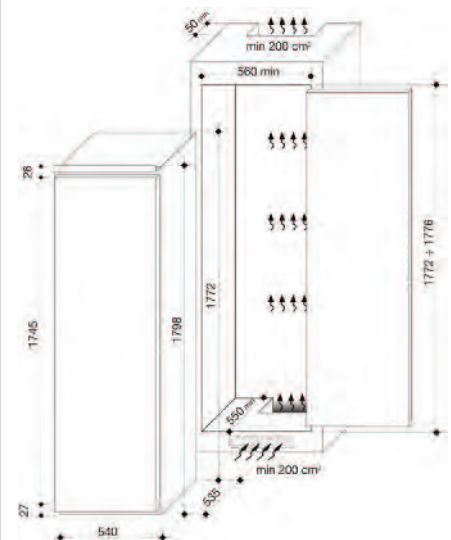

FULLY INTEGRATED FRIDGE / REFRIGERATION



CBL 150 E BUILT-IN LARDER FRIDGE

Total gross capacity 140 litres (4.95 cu.ft) > net refrigerator capacity 138 litres (4.9 cu.ft) > climate class N/ST > energy efficiency class A+ > automatic defrosting > glass shelves > reversible door > **housing dimensions** > height mm 874 ÷ 878 > width mm 560 > depth mm 550

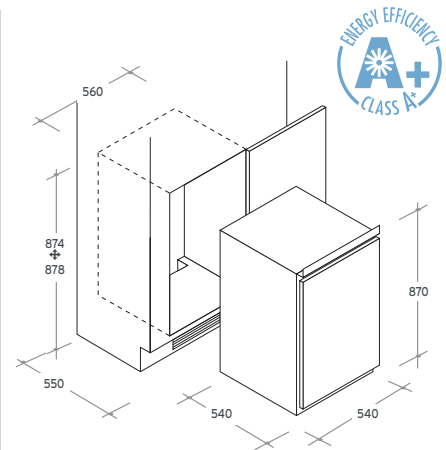

CRU 160 EK BUILT-UNDER LARDER FRIDGE

Total gross capacity 135 litres (4.77 cu.ft) > net refrigerator capacity 133 litres (4.7 cu.ft) > climate class N/ST > energy efficiency class A+ > automatic defrosting > reversible door > **housing dimensions** > height mm 820 ÷ 870 > width mm 600 > depth mm 550

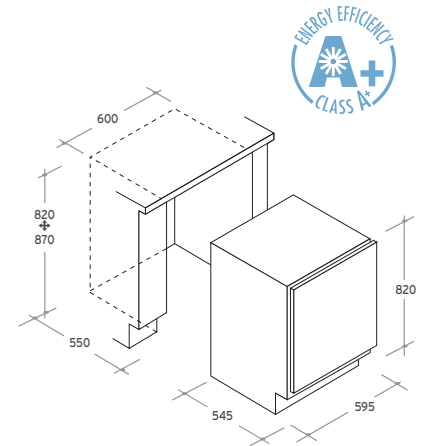

CRU 164 EK BUILT-UNDER REFRIGERATOR

Freezer rating. ❄️❄️❄️ > total gross capacity 119 litres (4.2 cu.ft) > net refrigerator capacity 100 litres (3.5 cu.ft) > net freezer capacity 17 litres (0.6 cu.ft) > climate class N/ST > energy efficiency class A+ > glass shelves > automatic fridge defrosting > reversible door > 24hr freezing capacity 2Kg > **housing dimensions** > height mm 820 ÷ 870 > width mm 600 > depth mm 550

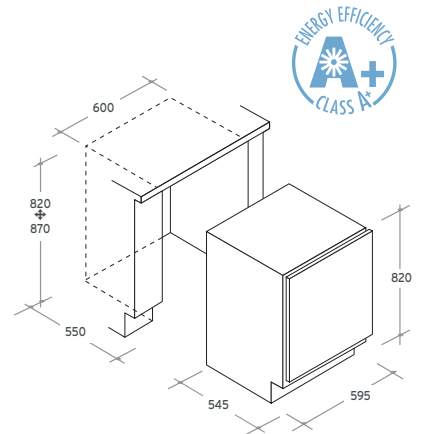

FULLY INTEGRATED FREEZER / REFRIGERATION



CFU 130 EK BUILT-UNDER FREEZER

Freezer rating. ❄️❄️❄️ > total gross capacity 103 litres (3.6 cu.ft) > net freezer capacity 97 litres (3.4 cu.ft) > 24 hr freezing capacity 5 Kg > climate class N/ST > energy efficiency class A+ > reversible door > manual defrosting > on/off - green light > fast freeze - yellow light > freezer warning - red light > **housing dimensions** > height mm 820 ÷ 870 > width mm 600 > depth mm 550

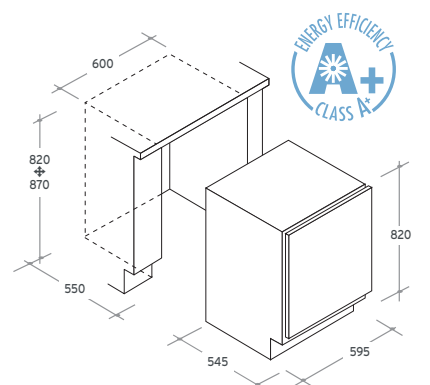

WINE COOLERS / REFRIGERATION



CCVB 110T BUILT-IN WINE COOLER

60cm wide > total capacity 110 litres > stores 24 bottles > 8 wooden shelves > blue LED light > adjustable temperature control 4-18 C

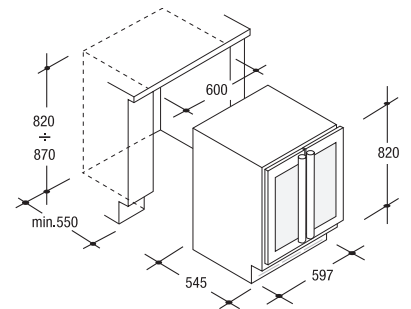

CCVB 120 BUILT-IN WINE COOLER

60cm wide > total capacity 120 litres > stores 35 bottles > LED display > 4 telescopic wooden shelves > blue LED light > adjustable temperature control 4 - 18°C

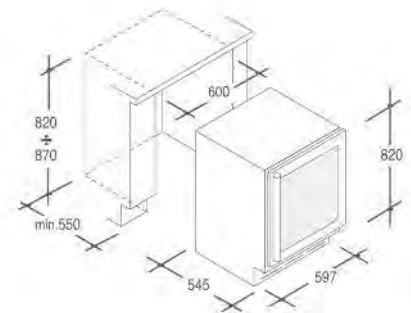

CCVB 60UK BUILT-IN WINE COOLER

30cm wide > total capacity 57 litres > stores 12 bottles > 4 wooden shelves > LED display > light > adjustable temperature control 4 - 18°C > front vent > adjustable feet

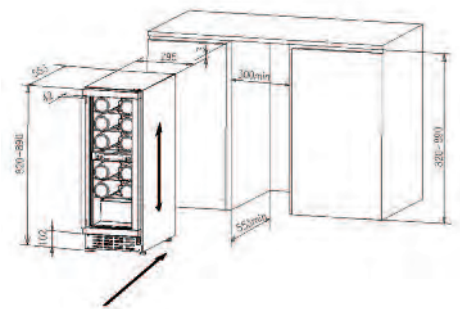

CCVB 25T UK BUILT-IN WINE COOLER

15cm wide > Total gross capacity 20 litres > stores 7 bottles > LED display with light > adjustable temperature control from 8 - 22°C transparent glass door > front vent

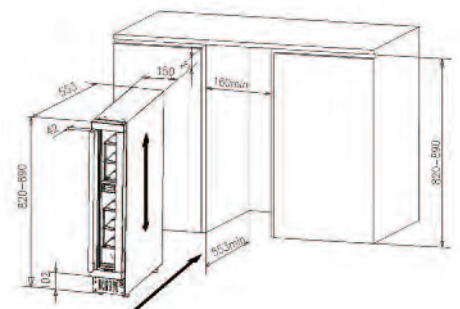

TECHNICAL SPECIFICATIONS / REFRIGERATION

Model	REFRIGERATION										
	CXSE7204	CKBC 3150E UK	CFBF 3050EK	CFBC 3050EK	CI0225E	CFLO 3550E	CFFO 3550E	CBL150E	CRU 164 EK	CRU160 EK	CFU130 EK
Product description	Side by Side Fridge Freezer	Fridge Freezer	Frost Free Fridge Freezer	Fridge Freezer	Built-in Refrigerator	Built-in Tall Larder	Built-in Tall Freezer	Built-in Larder	Built-under Refrigerator	Built-under Larder	Built-under Freezer
Main characteristics		***	***	***	***		***		***		***
Rapid freeze indicator light	-	-	-	-	-	-	•	-	•	-	••
Adjustable thermostat	•	•	•	•	•	•	•	•	•	•	•
Door shelves	5/5	4	3	3	3	5	-	3	2	2	-
Crisper	2	1	1	1	2	2	-	2	1	1	-
Glass shelves	4/3	4	4	4	4	5	-	3	1	2	-
Freezer Drawers	3	-	4	4	-	-	9	-	-	-	3
Reversible doors	-	•	•	•	•	•	•	•	•	•	•
Number of compressors	1	1	1	1	1	1	1	1	1	1	1
Technical Data											
Total gross capacity (l)	-	281	255	263	205	319	228	140	119	135	103
Net refrigerator capacity (l)	345	203	156	156	175	316	-	138	100	133	-
Net freezer capacity (l)	192	60	78	86	17	-	217	-	17	-	97
24 hr freezing capacity (kg)	10	3	4	4	2	-	10.5	-	2	-	6
Climatic class (l)	SN/ST	ST	SN/ST	ST	N/ST	ST	ST	N/ST	N/ST	N/ST	N/ST
Manual defrosting	-	•	-	•	•	•	•	-	•	-	•
Frost free	•	-	•	-	-	-	-	-	-	-	-
Rising time (h)	7	16	11	16	10	-	11	-	10	-	12
Annual consumption (kWh) (2)	445	283	294	283	204	151	291	126	185	123	193
Energy efficiency class (3)	A+	A+	A+	A+	A+	A+	A+	A+	A+	A+	A+
Noise level dB (A) (re 1 pw)	47	42	47	43	43	39	39	43	43	43	43
Appliance category (4)		7			7			1	7	1	8
Width of cavity (mm)	890	560	560	560	560	560	560	560	600	600	600
Min. depth of cavity (mm)	681	550	550	550	550	550	550	550	550	550	550
Height of cavity (mm)	1757	1772÷1776	1772-1776	1772-1776	1225÷1227	1772÷1776	1772÷1776	874÷878	820÷870	820÷870	820÷870

TECHNICAL SPECIFICATIONS / HOODS

MODEL	HOODS																		
	CIDT 61	CIDC 61	CDT 61	CDC 61	CMB950	CMB650	CVM970LX	CVMI970LX	CRD 93	CCR 616/1	CCT 985	CCT 685	CGM 91	CGM 61	CBG 620	CBP 612/1	CFT610/2		
Type	Island Tube	Island Cube	Tube	Cube	Décor	Décor	Décor	Island	Round	Décor	Round	Décor	Chimney	Chimney	Décor	Décor	Canopy	Integrated	Standard
Colour	X	X	X	X	X	X	X	X	X	X	X	X	X	X	X	X	W/N/S	W/N/GR	W/N/S
Motors (watts)	250	250	250	250	100	100	213	216	230	150	250	250	150	150	100	110	120		
Max air flow m3/h (ducted/recirculated)	520	710	520	710	550	550	750	750	550	450	850	850	450	450	170	230	180		
Lights	2 x 20w	4 x 20w	2 x 20w	2 x 20w	2 x 1.5 LED	2 x 1.5 LED	2 x 1.5 LED	4 x 1.5 LED	2 x 28w	2 x 28w	2 x 20w	2 x 20w	2 x 20w	2 x 20w	2 x 20w	2 x 28w	2 x 28w	2 x 28w	
	Halogen	Halogen	Halogen	Halogen	-	-	-	-	Halogen	Halogen	Halogen	Halogen	Halogen	Halogen	Halogen	Halogen	Halogen	Halogen	
Push button controls	-	-	-	-	X	X	-	-	X	X	X	X	X	X	-	-	-		
Touch control	X	X	X	X	-	-	X	X	-	-	-	-	-	-	-	-	-		
Slider controls	-	-	-	-	-	-	-	-	-	-	-	-	-	-	X	X	X		
Speeds	4	4	4	3	3	3	3	3	3	3	3	3	3	3	3	3	3		
Filter saturation indicator	X	X	X	-	-	-	-	-	-	-	-	-	-	-	-	-	-		
Timer	X	X	X	-	-	-	-	-	X	-	-	-	-	-	-	-	-		
Clean air function	X	X	-	-	-	-	-	-	X	-	-	-	-	-	-	-	-		
Washable metal grease filter	1	1	1	1	3	2	1	1	3	2	3	2	1	1	-	-	-		
Charcoal filter	Opt	Opt	Opt	Opt	Inc	Inc	Inc	Inc	Inc	Inc	Inc	Inc	Inc	Inc	Inc	Inc	Inc		
Air outlet diameter mm	150	150	150	150	150	150	150	150	150	150	150	150	150	150	123	120	125		
Noise level (sound pressure) dbA (ducted/recirculated)	50/51	55/56	50/51	55/56	-	-	-	-	52/56	50/52	58/62	58/62	52/54	52/54	-	52/55	-		
Noise level (sound power) db (A) (ducted/recirculated)	60/61	65/66	60/61	65/66	52/54	52/54	67/68	67/68	62/66	60/62	69/73	69/73	62/64	62/64	61/66	62/65	61/66		
Width cm	40	70	40	60	90	60	90	90	90	60	90	60	60	60	60	60	60		

SPLASHBACK

Model	PM60X
Height cm	65
Width cm	60
Depth cm	10

TECHNICAL SPECIFICATIONS / OVENS

Model	OVENS								
	FXLP 649RX	FXLP 649LX	FXP 649X	FXP 609	FVPE 729	FPE 609	FPE 409	FPE 403	FCL 614
Product description	Multi-function Maxi right Hinged	Multi-function Maxi Left Hinged	Multi-function Maxi	Multi-function Maxi	Multi-function Usee	Multi-function	Fan	Fan	Multi-function
Finish	X	X	X	X/NX	X	X	W/N/X	W/N/X	GH
Main characteristics									
Programme selector	Touch control programmer	Touch control programmer	Touch control programmer	Touch control programmer	Touch control	Electronic programmer	Touch control	End of Cooking	Analogue Clock
24 hour clock	•	•	•	•	•	•	•	-	-
Number of glass door panels	2	2	2	2	2	2	2	2	2
Grill	•	•	•	•	•	•	•	•	•
Thermostat	•	•	•	•	•	•	•	-	-
Shelves	2	2	2	2	2	1	2	2	2
Roasting tray	2	2	2	2	1	2	1	1	1
Self-cleaning panels	-	-	-	-	Opt.	Opt	Opt	Opt	-
Pyrolytic oven cleaning	-	-	-	-	-	-	-	-	-
Catalytic liners	•	•	•	-	-	-	-	-	-
AquaActiva cleaning system	-	-	-	-	•	•	-	-	-
Technical Data									
Volume (Litres)	73	73	73	78	69	65	65	65	65
Maximum temperature °C					245	245	245	245	243
Energy consumption static function (kWh)	0.80	0.80	0.80	0.80	0.80	0.80	0.80	-	0.79
Energy consumption fan convection(kWh)	0.90	0.90	0.90	0.90	0.90	0.90	0.90	0.80	0.99
Maximum absorbed power (kW)	2.1	2.1	2.1	2.1	2.1	2.2	2.1	0.90	2.1
Width of cavity mm	560	560	560	560	560	560	560	560	560
Height of cavity mm	590	590	590	590	585	585	585	585	585
Energy Classification	A	A	A	A	A	A+	A	A	A

Model	OVENS								
	FST 201	FDP 6109	FDP 232/2	TCP 6107	TCP 22/2	OVG 505/3	MIC 440 TX	MICG25GDFN	MIC20GDFX
Product description	Static	Multi-function Double Oven	Fan Double oven	Multi-function Double oven	Fan Double oven	Gas	Microwave plus grill	Microwave plus grill	Microwave plus grill
Finish	W/N/X	X/NX	X	X/NX	X	W/N/X	X	N	X
Main characteristics									
Main oven									
Programme selector	Minute Minder	Touch control	Touch control	Touch control	Electronic programmer	Timer	Electronic	Electronic	Electronic
Power levels	-	-	-	-	-	-	5	5	5
24 hour clock	-	•	•	-	•	-	•	•	•
Number of glass door panels	2	2	2	2	2	2	-	-	-
Grill	•	•	•	•	•	•	•	•	•
Turntable	-	-	-	-	-	-	•	•	•
Thermostat	-	-	-	-	-	-	•	•	•
Shelves	2	2	1	2	1	2	-	-	-
Roasting tray	1	1	1	1	1	1	-	-	-
Self-cleaning panels	Opt	-	-	-	-	-	-	-	-
Second oven									
Double glass	-	•	•	•	•	-	-	-	-
Grill	-	-	•	•	•	-	-	-	-
Shelves	-	1	1	1	1	-	-	-	-
Roasting tray	-	1	1	1	1	-	-	-	-
Technical data									
Volume (Litres)	65	54 + 39	54 + 39	43 + 39	43 + 39	50	44	25	20
Maximum temperature °C	245	230	230	230	230	240	220	220	220
Microwave power rating (W)	-	-	-	-	-	-	900	900	800
Energy consumption static function (kWh)	0.80	-	0.79	-	0.79	-	-	-	-
Energy consumption fan convection(kWh)	-	-	0.99	-	0.97	-	-	-	-
Maximum absorbed power (kW)	2.1	5.09	4.59	3.87	3.87	2.4	3.35	-	1.25
Width of cavity mm	560	564	554-564	566	554-564	560	560	560	560
Height of cavity mm	580	898	875-878	878	705-708	580	460	380	360
Energy Classification	A	A/A	B/A	A/A	B/A	A	-	-	-

TECHNICAL SPECIFICATIONS / HOBS

Model	GAS HOBS								
	CVG 75 SQPN	CPG 75 SQGX	CPG 75 SQPX	CPG 74 SQGX	CPGC 64 SQPGH	CPG 64 SP	CVG 64 SPN	CLG 64 SGX	CLG 64 SP
Product description	5 Gas	5 Gas	5 Gas	4 Gas	4 Gas	4 Gas	4 Gas	4 Gas	4 Gas
Finish	75cm N	75cm X	75cm X	75cm X	60cm GH	60cm B/N/X	60cm N	60cm X	60cm B/N/X
Main characteristics									
Quadruple ring burners	1	1	1	1	1	-	-	-	-
Ultra Rapid burner	-	-	-	-	-	-	-	-	-
Rapid burner	2	2	2	1	1	1	2	1	1
Semi-Rapid burner	1	1	1	1	1	2	2	2	2
Auxiliary burner	1	1	1	1	1	1	-	1	1
One touch ignition	•	•	•	•	•	•	•	•	•
Flame failure device	•	•	•	•	•	•	•	•	•
Cast iron pan supports	-	•	-	•	-	-	-	•	-
Enamel pan supports	•	-	•	-	•	•	•	-	•
Technical data									
Power developed burners (kW)	11.25	11.75	11.75	9.25	9.4	7.00	7.0	7.1	7.1
Quadruple burners (kW)	1x3.5	1x4	1x4	1x4	1x4	-	-	-	-
Ultra rapid burner (kW)	-	-	-	-	-	-	-	-	-
Rapid burners (kW)	2x2.5	2x2.5	2x2.5	1x2.5	1x2.7	1x2.5	1x2.5	1x2.7	1x2.7
Semi-Rapid burners (kW)	1x1.75	1x1.75	1x1.75	1x1.75	1x1.7	2x1.75	2x1.75	2x1.7	2x1.7
Auxiliary burners (kW)	1x1	1x1	1x1	1x1	1x1	1x1	1x1	1x1	1x1
Width of cavity (mm)	560	560	560	560	560	560	560	560	560
Depth of cavity (mm)	480	480	480	480	480	480	480	480	480
Width of product (mm)	745	750	750	750	745	590	595	595	595
Depth of product (mm)	510	510	510	510	510	510	510	510	510
Height of product (mm)	46	46	46	35	46	35	46	46	30

Model	CERAMIC / INDUCTION / ELECTRIC HOBS						
	CH 742	CH 642	CH 64M	CFID 36	CI 640 CBA	CI 640 C	PLE 64
Product description	75cm Hi-Light Ceramic	60cm Hi-Light Ceramic	60cm Hi-Light	60cm Flexi Induction	60cm Induction	60cm Induction	Electric
Finish	N	X/N	N/X	N	N	N	W/N/X
Main characteristics							
Cooking zones	4 Hi-Light 1x 190:1.8kW 1x 130/220:0.75/1.45kW 1x 180/275:0.9+1.5kW 1x 155:1.2kW	4 Hi-Light 1x155:1.2kW 1x 130/220:1.45+2.2kW 2x 190:1.8kW	4 Hi-Light 2x155:1.2kW 1x220:2.3kW 1x 190:1.8kW	4 Induction 2x200:1.5/2kW 2x200:2.3 or 1x190/400:3/3.6kW	4 Induction 1x 210:2.0kW 1x 180:2.0kW 2x 180:1.4kW	4 Induction 1x 210:2.0kW 1x 180:2.0kW 2x 180:1.4kW	4 Hotplates
Hotplates							2xØ180:2.0kW 2xØ145: 1.5kW
Digital touch controls	•	•	-	•	•	•	-
End of cooking timer	•	•	•	•	•	•	-
Hot hob warning lights	•	•	•	•	•	•	-
Installed electrical power (kW)	7.6	7.0	6.5	6.5	3.0		7.0
Width of cavity (mm)	560	560	560	560	560	560	560
Depth of cavity (mm)	490	490	490	490	490	490	480
Width of product (mm)	745	590	590	590	590	590	585
Depth of product (mm)	510	520	520	520	520	520	500
Height of product (mm)	50	50	50	50	50	50	30

TECHNICAL SPECIFICATIONS / WINE COOLERS

Model	WINE COOLERS								
	CCVB25T UK	CCVB60 UK	CCVB120	CCVB110	Model	CCVB 25T UK	CCVB 60 UK	CCVB 120	CCVB 110
Width	15cm	30cm	60cm	60cm	Front Vent	•	•	•	•
Total gross capacity	20	57	120	110	Adjustable feet	•	•	•	•
Bottle storage capacity	7	12	35	24	Height (mm)	820-890	820-890	820-890	820-890
LED display with light	•	•	•	•	Width	150	295	597	597
Adjustable temperature control	8-22	4-18	4-18	4-18	Depth	553	553	550	550

TECHNICAL SPECIFICATIONS / DOMINO HOBS

Model	DOMINO HOBS									
	CDG 31/1 SPX	CDG 32/1 SPX	CDI 32/1 B	CDH 32/1 X	CDH 32/1 C	CDE 32/1 X	CDVG 30/1 X	CDB 30/1 X	CDF 30/1X	
Product Description	Gas Hob	Gas Hob	Induction Hob	Ceramic Hob	Ceramic Hob	Electric Hob	Griddle	BBQ	Fryer	
Finish	X	X	B	X	B	X	X	X	X	
Cooking Zones / Burners	1	2	2	2	2	2	1	1	-	
Flame Failure	•	•	-	-	-	-	-	-	-	
Controls	One touch	One touch	Digital touch control	Knobs	Digital touch control	Knob	Knob	Knob	Knob	
Technical data										
Installed electrical power (kW)	-	-	3.7	3	3	3	1.5	2.4	2.3	
Power developed burners (kW)	3.5	4	-	-	-	-	-	-	-	
Width of cavity (mm)	270	270	270	270	270	270	270	270	270	
Depth of cavity (mm)	494	494	490	490	490	490	490	494	494	
Width of product (mm)	290	290	288	288	288	288	228	288	288	
Depth of product (mm)	510	510	506	510	506	510	510	510	510	
Height of product (mm)	45	40	42	45	42	45	45	50	155	

TECHNICAL SPECIFICATIONS / LAUNDRY

Model	LAUNDRY												
	CDB 854	CDB 754ND/1	CDB 264N	CWB 814DN1	CWB 7143DN1	CWB 1462DN1	Technical data	CDB 854	CDB 754ND/1	CDB 264N	CWB 814DN1	CWB7143DN	CWB 1462DN1
Product description	Washer dryer	Washer dryer	Washer dryer	Washing machine	Washing machine	Washing machine	Energy efficiency class	B	A	B	A+	A+	A+
Main characteristics							Wash efficiency class	A	A	A	A	A	A
Washing capacity (kg)	8	7	6	8	7	6	Spin efficiency class	A	A	B	A	A	B
Drying capacity (kg)	5	5	4	-	-	-	Energy consumption 60°C wash - full load	1.36	-	-	1.43	1.25	1.05
Washing/drying prog	12/3	12/2	12/2	12	13	15	Energy consumption 60°C wash partial load	-	-	-	0.97	0.87	.79
Rapid programme	14/30/44	14/30/44	30	14/30/44	14/30/44	30	Energy consumption 40°C wash partial load	-	-	-	0.78	0.71	0.63
Spin speed (rpm.)	1400	1400	1200	1400	1400	1400	Energy consumption wash - & dry full load kWh	5.44	5.65	5.1	-	-	-
Stainless Steel drum	•	•	•	•	•	•	Water consumption standard- 60°C cycle litres	115***	103***	110***	48	44	41
Fuzzy logic	•	•	•	•	•	•	Annual water consumption wash only	9000**	11000**	9800**	10500	9600*	8900*
Internal steam condensing	•	•	•	-	-	-	Annual water consumption wash & dry	23000	20600	22000	-	-	-
Automatic variable capacity	•	•	•	•	•	•	Moisture content on dry load after max spin according to regulations	-	59%	53%	44%	44%	53%
Variable spin speed	•	•	•	•	•	•	Voltage V	230	230	230	230	230	230
Drying time selector	•	•	•	-	-	-	Max absorbed power kW	5.55	5.55	5.5	2.15	2.15	2.15
Independent temp regulator	•	•	•	•	•	•	Fuse rating A	13	13	13	13	13	13
Stain blaster button	•	•	•	•	•	•	Spin db(A)	58	76	73	58	79	75
Allergy care button	•	•	•	•	•	•	Wash db(A)	76	60	60	76	58	58
High dry button	•	•	•	-	-	-	Height mm	820	820	820	820	820	820
Cold fill only	•	•	•	•	•	•	Width mm	596	596	596	596	596	596
Adjustable feet	•	•	•	•	•	•	Depth mm	541	541	541	541	541	541
							Width of cavity mm	600	600	600	600	600	600
							Depth of cavity mm	570	570	570	570	570	570
							Height of cavity mm	825	825	825	825	825	825

* annual estimated consumption for 220 loads on a washing machine

** annual estimated consumption for 200 loads on a washer dryer

***washing and drying cycle

TECHNICAL SPECIFICATIONS / DISHWASHERS

Model	DISHWASHERS								
	CDIM 3653	CDI CDI 1012/4	CDS 420	CDI 4545/E	Technical data	CDIM 3653	CDI CDI 1012/4	CDS 420	CDI 4545/E
Finish	W	W	X/N	W	N° of IEC place settings	15	12	12	9
Main characteristics					N° of programmes	6	5	7	7
Adjustable upper basket	•	•	•	•	Wash temperatures	75/60	5/65	75/65	70/55/
AISI 304 stainless steel interior	•	•	•	•		50/45	50/45	60/50/45	50/45
Double anti-overflow device	•	•	-	•	Water consumption (litres - IEC)	10	2	12	10
Anti flood device	•	-	-	•	Energy consumption (kW/h IEC)	1.00	1.07	1.04	0.79
Start delay	•	-	-	•	Noise power dB (A) (re 1 pw)	44	53	53	54
Self-cleaning microfilter	•	-	-	•	Energy efficiency class	A+	A+	A+	A+
Rapid programme (mins)	32	32	32	32	Wash efficiency class	A	A	A	A
Half load button	-	-	-	-	Drying efficiency class	A	A	A	A
Delicate button	-	-	-	-	Width of cavity (mm)	600	600	600	450
Economy button	-	-	-	-	Depth of cavity (mm)	570	570	570	600
Salt consumption light	•	•	•	•	Height of cavity (mm)	820÷885	820÷885	820÷885	820÷885
Balanced door	•	•	•	•					
Height adjustable feet	•	•	•	•					

TECHNICAL SPECIFICATIONS / DUO AND TRIO RANGE

Model	DUO AND TRIO			
	DUO 609	TRIO 9503	DUO 609	TRIO 9503
Product description	Oven dishwasher	Oven, hob, dishwasher	Dishwasher	
Finish	X	X	Number of IEC place settings	6
Hob			Number of programmes	6
4 gas burners		-	Water consumption (litres - IEC)	9
Flame failure device		-	Rapid programme (mins)	32
One touch ignition		-	Anti-overflow device	•
Enamelled pan supports		-	Energy efficiency class	A
4 hi-light zones		•	Wash efficiency class	A
Oven			Drying efficiency class	A
Multi-function oven	•	•	Dimensions	
Grill	•	•	Height (mm) with adjustable legs	835-900
Timer	-	End of cooking	Width (mm)	596
Number of glass door panels	2	2	Depth (mm)	570
Volume (litres)	39	39		
Energy classification	A	A		

TECHNICAL SPECIFICATIONS / WARMING DRAWER

Model	WARMING DRAWER		
	RDCT 140/1MIN		
Keep warm programme	•	Max capacity	25kg
Pre-heating crockery	•	Max absorbed power	620W
Temp adjustable from 30-80°C	•	Dimensions	
Anti-slip mat	•	Height (mm)	140
Illuminated on/off switch	•	Width (mm)	594
Telescopic pull-out drawer	•	Depth (mm)	535

TECHNICAL SPECIFICATIONS / RANGE COOKER

Model	RANGE COOKER						
	CCG 9M52 PX	CCG 9D52 PX	CCV 9D52 X	Model	CCG 9M52 PX	CCG 9D52 PX	CCV 9D52 X
Product Description	Range Cooker	Range Cooker	Range Cooker	Additional features			
Finish	X	X	X	Adjustable feet	•	•	•
Main characteristics				Storage drawer	•	•	•
Oven programme type	LED	LED	LED	Technical data			
Multi-function main oven	•	•	•	Volume (litres) - main oven	108	51	51
Conventional second oven	-	-	-	Volume (litres) - second oven	-	35	35
Grill	•	•	•	Depth mm	600	600	600
24 hour clock	•	•	•	Width mm	900	900	900
5 burner gas hob	•	•	•	Height mm	917-972	917-972	917-972
5 ceramic zones	-	-	•	Energy efficiency classification	A	A/A	A/A
Flame failure device	•	•	-				
Baking tray	1	1	1				
Shelves main oven	2	2	2				
Shelves second oven	-	2	1				
Flat glass inner door	•	•	•				

X - Stainless Steel NX - Black and Stainless Steel S - Silver N - Black W - White GR - Grey GH - Charcoal

All Candy appliances come with a free five year's parts guarantee when you register your purchase. What's more the comprehensive Candy After Sales Service Promise covers every eventuality. So, in the unlikely event of a fault occurring there's no need to worry - we take care of everything.



Candy Advice Line
08444 995599

Republic of Ireland
Telephone: (00353) 818 200021



Group activities including all factories and the organisation structure are ISO 9001 accredited.

Candy's policy is one of continuous improvement, therefore we reserve the right to modify or alter specifications without prior notice. All products subject to availability.



CANDY BUILT-IN APPLIANCES DIVISION

New Chester Rd - Bromborough - Wirral - CH62 3PE

Telephone: 0151-334 2781 - Fax: 0151-334 9056

Website: www.candy-domestic.co.uk

12/14

