



Designer cooker hoods

best



Fly HOOD-BE-FY-11-SS

BEST by name ...

We think that a cooker hood should be a focal point of a kitchen, not an afterthought. By combining elegant design and uncompromising performance, a hood can meet the demands of modern living and provide inspiration in a space that's designed for creativity. It's not just the best way, it's the BEST way.

It's an approach that's served us well for over 30 years. We continue to innovate in order to produce beautiful hoods that quietly, efficiently purify the air and enhance the ambience of your kitchen.

Our collection reflects the latest interior trends, offering greater design freedom than ever before. As BEST products are distributed and fully supported by Britannia Living - one of the most trusted names in kitchen design - you benefit from excellent, reliable service, so you can easily create your dream kitchen, with more than a little help from BEST.



best

britannia

Ceiling



Enigma p10



Cirrus Glass p11



Cirrus p12



Visso p13

Pendant



Double Vertigo p16



Sphera p18



Vintage p19



Outline p20

Island



Collier Island p26



Fly p27



Polar Island p28



Spark p29

Wall mounted

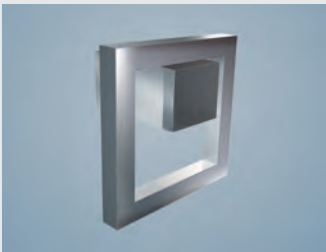

Collier p34



Overside p35



Fusion p36



Fluttua p37



Kubi p42

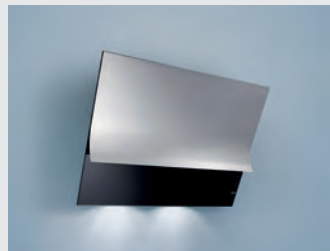

Surf p43



Kite p44



Kite Small p45

Downdraft



Lift p52



Movie p53



Gemini p21



Moon p22



Cube p23



Lampedusa p30



Smooth p38



Shelf p39



Polar p40



Keys p41



Etna p46



Latina p47



Cricket p48



Nettuno p49

Discover the features and unique innovations that help make BEST cooker hoods the best choice for your home.



Advanced Sensor Control

Thanks to sophisticated technology, our patented Advanced Sensor Control automatically switches on the hood when odours, gas, steam or smoke are detected by the sensors. The correct speed is automatically regulated and extraction will continue for a few minutes after all residual odours have been eliminated. Manual operation can be achieved at the touch of a button.



Energy saving

BEST has created a new type of three-phase electronic motor which allows an average energy saving of 55% compared to traditional motors. The introduction of this type of technology makes BEST the first producer in the world to have introduced an 'Energy Class A' extractor hood according to current standards.



Wave filter

This unique 3 dimensional filter system reduces the amount of space required for the filter while increasing the surface area. This improves the aesthetic appearance of the hood and allows quieter performance and more efficient grease capture.



BEST Silent Tech

BEST hoods featuring Silent Tech are amongst the most silent on the market today, thanks to its sophisticated soundproofing and uniquely developed grease filters. This allows for almost imperceptible noise levels at low speeds, reducing sound output by 36% compared to traditional extraction systems, whilst maintaining high airflow rates and performance.



Perimeter extraction

Perimeter extraction is a system whereby smoke, steam and odours are forced to go through apertures placed along the perimeter of the hood. This creates greater efficiency, quieter performance and improved aesthetics by hiding the grease filters.



Remote control

BEST's stylish remote control is ergonomic, allowing the user to operate the main functions of the hood.



Reversible motor

A reversible motor offers an aesthetically pleasing alternative for ducting out. BEST hoods that feature a reversible motor can duct out through the top of the hood, when used with a chimney kit; or straight through an external wall, removing the need for a chimney kit. This complements their streamline designs.



Timer

The timer function allows a run-on time to be set at an adjustable speed so that the hood will automatically switch off 5 minutes after cooking, allowing the air to be fully cleared.



LED technology

Besides purifying the air, BEST hoods create ambience and lighting for the cooking area. Certain models feature energy saving LED lighting. Each light only requires 3 watts compared to 20 watts for halogen lights, and has a life span of up to 40,000 hours.

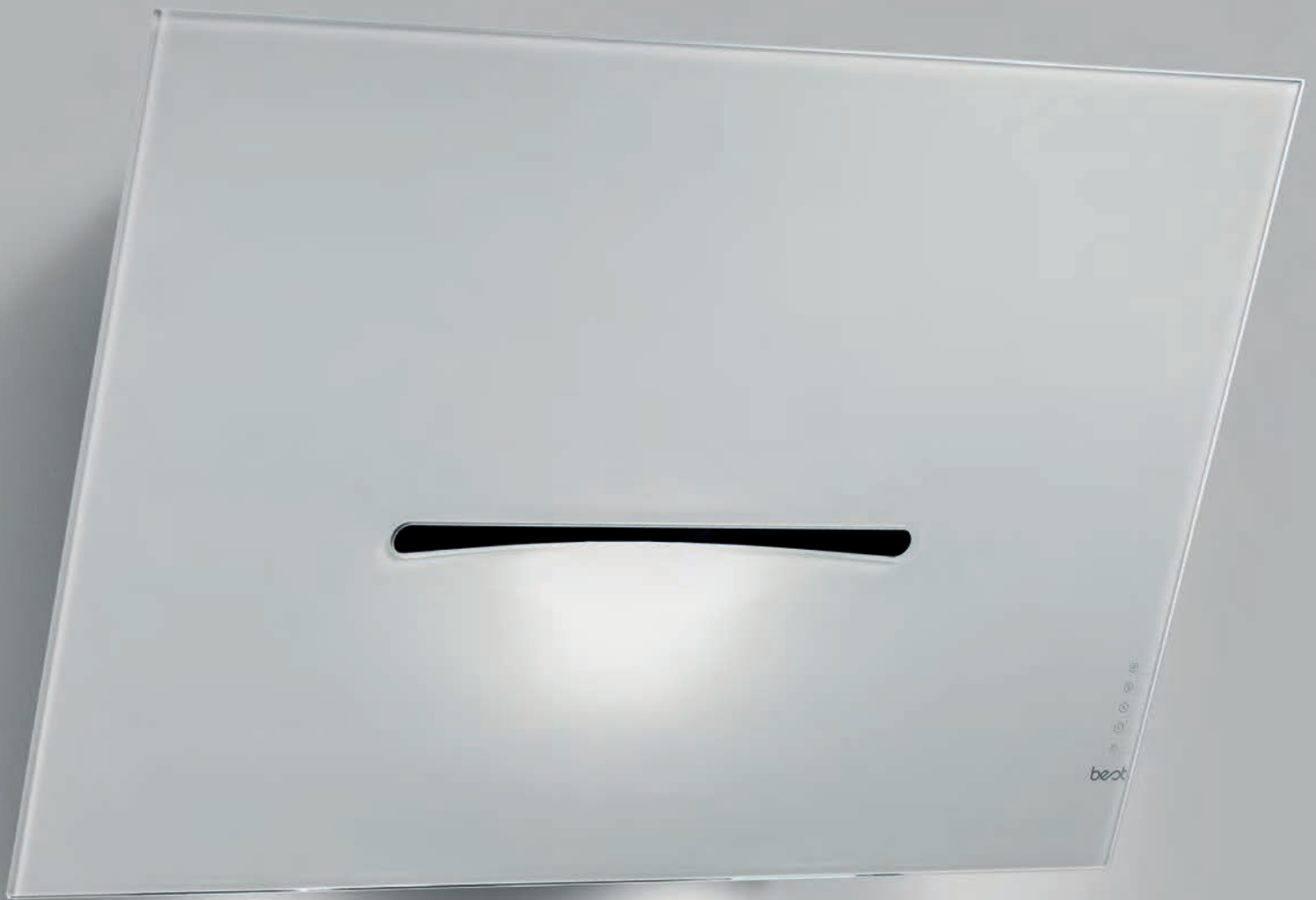

Controls

Electronic light touch

This new circular ergonomic control is both aesthetically pleasing and easy to use. The 4 extraction speeds are indicated through colour change, and functions include; timer, filter alarm and in some cases Advanced Sensor Control.



Electronic soft touch

Available on several BEST models, the electronic backlit 4 speed button panel is timer equipped for automatic switch off and is a design feature in its own right.

Electronic slim

This control panel is both minimalist and aesthetically pleasing thanks to advanced technology. Its 7 buttons allow control of the lighting, the 4 speeds, the timer function for automatic switch off and in some cases Advanced Sensor Control. LEDs indicate which function is in operation.

Touch control

Touch screen technology is incorporated in this smooth and minimalist design. By touching the etched symbols on the glass, you have control of the 4 speeds and timer function and in some cases Advanced Sensor Control.

External or remote motors

Many BEST models can be equipped with either an external or remote motor.

Both the external and remote motors are housed in stainless steel boxes. For an external motor the box can be sited outside the house, for instance on the roof or on a wall. For a remote motor, the box can be positioned inside the house such as in the attic or in an adjacent space.

The advantage of these options is the reduction in noise while maintaining maximum efficiency.



Ceiling

Ceiling hoods are perfect for above cooking islands, ideal for minimalist open-plan living. Combining subtle design and high performance, BEST ceiling hoods all feature contemporary LED lighting and a remote control for convenient operation. The Visso canopy hood sits neatly under a cabinet or chimney mantel and provides discreet extraction when a ceiling hood isn't practical.





Enigma

Product	Code
Enigma	HOOD-BE-EN-12-WH

Features
LED technology
Perimeter extraction
Timer
Remote control included

Description	
Installation	Ceiling built-in
Size	ø 1100mm
Nett weight	68kg
Finish	Painted white
Controls	Electronic light touch
Lighting	LED 12 x 3W

Extraction performance	
Speeds	4
Airflow	910m ³ /h
Max noise level	66dB
Min noise level	49dB
Total wattage	374W
Grease filter	Aluminium grid filter

Extraction	
Ducted out	Requires ø 150mm ducting

Optional accessories	Code
Remote control (re-order only)	HOOD-BE-AC-REM

Further ducting information can be found on pages 54-57



Cirrus Glass

Product Code

Motor included	
Cirrus Glass	HOOD-BE-CI-11-GL
Nett weight	23.9kg

Motor not included	
Cirrus Glass	HOOD-BE-CE-11-GL
(external or remote motor)	
Nett weight	21.5kg

Motors	
External motor	HOOD-BE-AC-EX-MO
Remote motor	HOOD-BE-AC-RE-MO

Features

- LED technology
- Perimeter extraction
- Remote control included
- Timer

Description

Installation	Ceiling
Size	1100 x 700mm
Finish	Stainless steel and glass
Control	Electronic light touch
Lighting	LED 6 x 3W

Extraction performance

Speeds	4
Airflow	840 m ³ /h
Max noise level	69dB
Min noise level	61dB
Total wattage	278W
Grease filter	Aluminium grid filter

Extraction options

Ducted out	Requires ø 150mm ducting
External or	
Remote motor	Requires ø 150mm ducting

Optional accessories Code

Remote control	
(re-order only)	HOOD-BE-AC-REM
For roof adapter	
(external motor only)	HOOD-BE-AC-RF

Further ducting information can be found on pages 54-57



Cirrus

Product	Code
Motor included	
Cirrus	
Stainless steel	HOOD-BE-CI-11-SS
Nett weight	23.9kg

Motor not included	
Cirrus	(external or remote motor)
Stainless steel	HOOD-BE-CE-11-SS
Nett weight	21.5kg

Motors	
External motor	HOOD-BE-AC-EX-MO
Remote motor	HOOD-BE-AC-RE-MO

Features
LED technology
Perimeter extraction
Remote control included
Timer

Description	
Installation	Ceiling built-in
Size	1100 x 700mm
Finish	Stainless steel
Controls	Electronic light touch
Lighting	LED 6 x 3W

Extraction performance	
Speeds	4
Airflow	840m ³ /h
Max noise level	69dB
Min noise level	61dB
Total wattage	278W
Grease filter	Aluminium grid filter

Extraction options	
Ducted out	Requires ø 150mm ducting
External or	
Remote motor	Requires ø 150mm ducting

Optional accessories	Code
Remote control (re-order only)	HOOD-BE-AC-REM
For roof adapter (external motor only)	HOOD-BE-AC-RF

Further ducting information can be found on pages 54-57



Visso

Product Code

Visso 52cm		
Stainless steel	HOOD-BE-VS-52-SS	
Nett weight		9.5kg

Visso 70cm		
Stainless steel	HOOD-BE-VS-70-SS	
Nett weight		12kg

Features

Advanced Sensor Control
Perimeter extraction

Description

Installation	Canopy
Size	520 - 700mm
Finish	Stainless steel
Controls	Electronic slim
Lighting	Halogen 2x20W

Extraction performance

Speeds	4
Airflow	630m ³ /h
Max noise level	69dB
Min noise level	49dB
Total wattage	290W
Grease filter	Aluminium grid filter

Extraction options

Ducting out	Requires ø 150mm ducting
Recycling	Requires charcoal filter

Optional accessories

Charcoal filter	HOOD-BE-AC-FI-LA
-----------------	------------------

Further ducting and recycling information can be found on pages 54-57



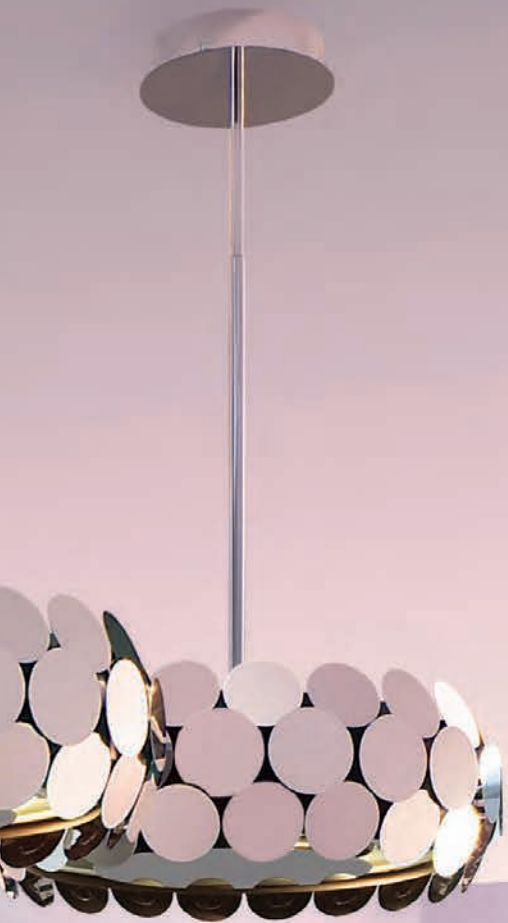

Pendant

Pendant hoods represent an impressive focal point in your kitchen and look particularly effective in pairs over larger hobs or dual sited over the hob and dining table. Vintage is a striking original cooker hood which complements even the most stylish of kitchen designs. Many of the designs can be adjusted to suit the height of the kitchen for a truly unique look.



Vintage HOOD-BE-VI-63-SS

Double Vertigo

Product	Code
Double Vertigo Stainless steel	HOOD-BE-VED-10-S

Features
Perimeter extraction
Timer
Remote control - optional

Description
Installation Ceiling
Size 1000 x 500mm
Nett weight 34.5kg
Finish Polished stainless steel
Controls Electronic soft touch
Lighting Halogen 6 x 20W

Extraction performance
Speeds 4
Airflow 780m ³ /h
Max noise level 72dB
Min noise level 49dB
Total wattage 300W
Grease filter Aluminium grid filter

Extraction
Recycling Charcoal filter included

Optional accessories	Code
Charcoal filter (re-order only)	HOOD-BE-AC-FI-SW
Remote control	HOOD-BE-AC-REM

Further recycling information can be found on page 54-57





Sphera

Product	Code
Sphera Chrome	HOOD-BE-SH-50-CH

Features
Timer
Remote control - optional

Description	
Installation	Ceiling
Size	ø 500mm
Nett weight	17kg
Finish	Chrome
Controls	Electronic soft touch
Lighting	Halogen 2 x 20W
Pole included for ceiling height 2.4m to 2.8m	

Extraction performance	
Speeds	4
Airflow	390m ³ /h
Max noise level	67dB
Min noise level	49dB
Total wattage	190W
Grease Filter	Aluminium grid filter

Extraction	
Recycling	Charcoal filter included

Optional accessories	Code
Charcoal filter (re-order only)	HOOD-BE-AC-FI-SH
Remote control	HOOD-BE-AC-REM

Shortening pole kit for ceiling height 2.08m to 2.3m	HOOD-BE-AC-PL-SH
---	------------------

Lengthening pole kit for ceiling height 2.9m to 3.6m	HOOD-BE-AC-PL-LG
---	------------------

Further recycling information can be found on page 54-57

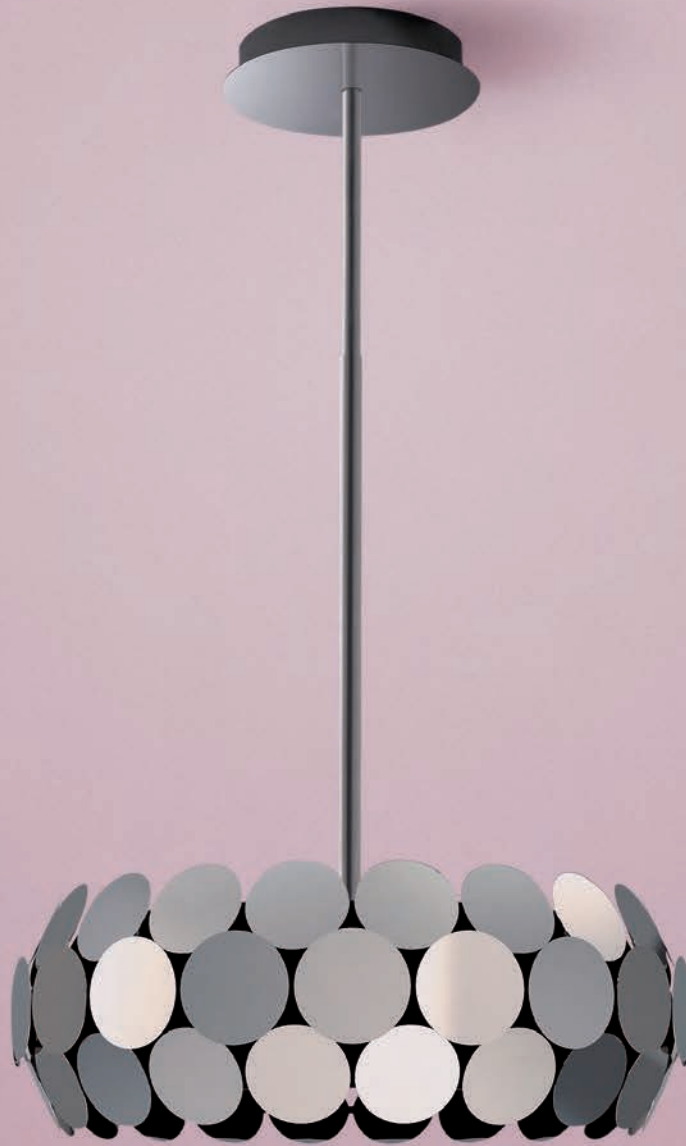

Vintage

Product	Code
Vintage	
Stainless steel	HOOD-BE-VI-63-SS

Features
Perimeter extraction
Timer
Remote control - optional

Description	
Installation	Ceiling
Size	ø 630mm
Nett weight	22.5kg
Finish	Polished stainless steel
Controls	Electronic soft touch
Lighting	Halogen 3 x 20W
Pole included for ceiling height 2.4m to 2.8m	

Extraction performance	
Speeds	4
Airflow	390m ³ /h
Max noise level	69dB
Min noise level	47dB
Total wattage	150W
Grease filter	Aluminium grid filter

Extraction	
Recycling	Charcoal filter included

Optional accessories	Code
Charcoal filter (re-order only)	HOOD-BE-AC-FI-SW
Remote control	HOOD-BE-AC-REM
Shortening pole kit for ceiling height 2.08m to 2.3m	HOOD-BE-AC-PL-SH
Lengthening pole kit for ceiling height 2.9m to 3.6m	HOOD-BE-AC-PL-LG

Further recycling information can be found on page 54-57



Outline

Product Code

Outline
Stainless steel HOOD-BE-OU-90-SS

Features

Perimeter extraction
Timer
Remote control - optional

Description

Installation Ceiling
Size 900mm
Nett weight 19.5kg
Finish Polished stainless steel
Controls Electronic soft touch
Lighting Halogen 5 x 20W
Poles included for ceiling height 2.4m to 2.8m

Extraction performance

Speeds 4
Airflow 780m³/h
Max noise level 72dB
Min noise level 49dB
Total wattage 300W
Grease filter Aluminium grid filter

Extraction

Recycling Charcoal filter included

Optional accessories

	Code
Charcoal filter (re-order only)	HOOD-BE-AC-FI-SW
Remote control	HOOD-BE-AC-REM
Shortening pole kit for ceiling height (x2) 2.08m to 2.3m	HOOD-BE-AC-PL-SH
Lengthening pole kit for ceiling height (x2) 2.9m to 3.6m	HOOD-BE-AC-PL-LG

Further recycling information can be found on page 54-57



Gemini white

Gemini

Product	Code
Gemini black	HOOD-BE-GE-65-BL
Gemini white	HOOD-BE-GE-65-WH

Features
Perimeter extraction
Timer
Remote control - optional

Description	
Installation	Ceiling
Size	ø 655mm
Nett weight	19.5kg
Finish	Painted aluminium
Controls	Electronic soft touch
Lighting	Halogen 3 x 20W
Pole included for ceiling height	2.4m to 2.8m

Extraction performance	
Speeds	4
Airflow	390m3/h
Max noise level	69dB
Min noise level	47dB
Total wattage	150W
Grease filter	Aluminium grid filter

Extraction	
Recycling	Charcoal filter included

Optional accessories	Code
Charcoal filter (re-order only)	HOOD-BE-AC-FI-SW
Remote control	HOOD-BE-AC-REM

Shortening pole kit for ceiling height 2.08m to 2.3m	HOOD-BE-AC-PL-SH
--	------------------

Lengthening pole kit for ceiling height 2.9m to 3.6m	HOOD-BE-AC-PL-LG
--	------------------

Further recycling information can be found on page 54-57



Moon black



Moon white

Moon



Product	Code
Moon	
Stainless steel	HOOD-BE-MO-50-SS
Moon black	HOOD-BE-MO-50-BL
Moon white	HOOD-BE-MO-50-WH

Features
Perimeter extraction
Timer
Remote control - optional

Description	
Installation	Ceiling
Size	ø 500mm
Nett weight	18.5kg
Finish	Polished stainless steel, white or black
Controls	Electronic soft touch
Lighting	Halogen 3 x 20W
Pole included for ceiling height	2.4m to 2.8m

Extraction performance	
Speeds	4
Airflow	390m ³ /h
Max noise level	69dB
Min noise level	47dB
Total wattage	150W
Grease filter	Aluminium grid filter

Extraction	
Recycling	Charcoal filter included

Optional accessories	Code
Charcoal filter (re-order only)	HOOD-BE-AC-FI-SW
Remote control	HOOD-BE-AC-REM

Shortening pole kit for ceiling height 2.08m to 2.3m	HOOD-BE-AC-PL-SH
--	------------------

Lengthening pole kit for ceiling height 2.9m to 3.6m	HOOD-BE-AC-PL-LG
--	------------------

Further recycling information can be found on page 54-57



Cube black

Cube

Product	Code
Cube black	HOOD-BE-CU-40-BL
Cube white	HOOD-BE-CU-40-WH

Features
Timer
Remote control - optional

Description	
Installation	Ceiling
Size	400 x 400mm
Nett weight	15kg
Finish	Painted black/painted white
Control	Electronic soft touch
Lighting	Halogen 2 x 20W

Extraction performance	
Speeds	4
Airflow	480m ³ /h
Max noise level	66dB
Min noise level	49dB
Total wattage	230W
Grease filter	Aluminium grid filter

Extraction	
Recycling	Charcoal filter included

Optional accessories	Code
Charcoal filter (re-order only)	HOOD-DE-AC-FI-SL

Further ducting and recycling information can be found on pages 54-57





Island

BEST island hoods demonstrate the perfect mix of form and function to complement the style and convenience offered by island units. With the reassurance of technical excellence, teamed with stunning good looks, BEST provides a real statement in your kitchen.



Collier Island

Product	Code
Collier Island	HOOD-BE-CO-11-SS

Features
 LED technology
 Advanced Sensor Control
 Remote control - optional

Description	
Installation	Ceiling
Size	1100mm
Nett weight	29.5kg
Finish	Polished stainless steel
Control	Electronic soft touch
Lighting	LED 3 x 3W

Extraction performance	
Speeds	3
Airflow	770m ³ /h
Max noise level	69dB
Min noise level	48dB
Total wattage	259W
Grease filter	Stainless steel grid filter

Extraction options	
Ducted out	Requires ø 150mm ducting
Recycling	Charcoal filter included

Optional accessories	Code
Charcoal filter (re-order only)	HOOD-BE-AC-FI-LA
Remote control	HOOD-BE-AC-REM

Further ducting information can be found on pages 54-57



Fly



Product	Code
Fly	HOOD-BE-FY-11-SS

Features
Perimeter extraction
LED technology
Energy saving product
Remote control - optional

Description	
Installation	Ceiling
Size	1100mm
Nett weight	46.5kg
Finish	Stainless steel and glass
Control	Electronic soft touch
Lighting	LED 6 x 3W

Extraction performance	
Speeds	4
Airflow	940m ³ /h
Max noise level	73dB
Min noise level	40dB
Total wattage	278W
Grease filter	Aluminium grid filter

Extraction options	
Ducted out	Requires ø 150mm ducting
Recycling	Requires charcoal filter

Optional accessories	Code
Charcoal filter (re-order only)	HOOD-BE-AC-FI-LA
Remote control	HOOD-BE-AC-REM

Further ducting information can be found on pages 54-57



Polar Island white



Wave filter

Polar Island

Product	Code
Polar Island black	HOOD-BE-POI-90-B
Polar Island white	HOOD-BE-POI-90-W

Features
BEST Silent Tech
Energy saving product
Perimeter extraction
Timer
Wave filter

Description	
Installation	Ceiling
Size	900 x 600mm
Nett weight	29.5kg
Finish	Stainless steel and glass
Controls	Electronic light touch
Lighting	Halogen 4 x 20W

Extraction performance	
Speeds	4
Airflow	800m ³ /h
Max noise level	60dB
Min noise level	41dB
Total wattage	280W
Grease filter	Aluminium grid filter

Extraction options	
Ducting out	Requires ø 150mm ducting
Recycling	Requires charcoal filter

Optional accessories	Code
Charcoal filter	HOOD-BE-AC-FI-PO

Further ducting and recycling information can be found on pages 54-57



Wave filter

Spark



Product	Code
Spark	
Stainless steel	HOOD-BE-SPI-10-S

Features
BEST Silent Tech
Energy saving product
LED technology
Perimeter extraction
Timer
Wave filter

Description	
Installation	Ceiling
Size	1000 x 700mm
Nett weight	30.5kg
Finish	Stainless steel and glass
Controls	Electronic slim
Lighting	LED 4 x 3W

Extraction performance	
Speeds	4
Airflow	800m ³ /h
Max noise level	60dB
Min noise level	41dB
Total wattage	212W
Grease filter	Aluminium grid filter

Extraction options	
Ducting out	Requires ø 150mm ducting
Recycling	Requires charcoal filter

Optional accessories	Code
Charcoal filter	HOOD-BE-AC-FI-PO

Further ducting and recycling information can be found on pages 54-57



Lampedusa

Product	Code
Lampedusa	
Stainless steel	HOOD-BE-LP-32-SS

Features
Timer

Description
Installation
Size
Nett weight
Finish
Controls
Lighting

Ceiling
 ø 320mm
 22.6kg
 Stainless steel
 Electronic slim
 Halogen 2 x 20W

Extraction performance
Speeds
Airflow
Max noise level
Min noise level
Total wattage
Grease filter

4
 630m3/h
 67dB
 50dB
 290W
 Aluminium grid filter

Extraction options
Ducting out
Recycling

Requires ø 150mm ducting
 Requires charcoal filter

Optional accessories	Code
Charcoal filter	HOOD-BE-AC-FI-LM

Further ducting and recycling information can be found on pages 54-57



Lampedusa HOOD-BE-LP-32-SS





Wall mounted

While wall mounted hoods may be those most commonly found in kitchens, there is nothing ordinary about BEST wall mounted designs. Our collection represents a diverse range of design-led styles to suit current kitchen trends, while cutting-edge technology ensures that their beauty is matched by their power.



Collier

Product	Code
Collier	HOOD-BE-CO-90-SS

Features
LED technology
Advanced Sensor Control
Remote control - optional
Reversible motor

Description	
Installation	Wall mounted
Size	900mm
Nett weight	24.5kg
Finish	Polished stainless steel
Control	Electronic soft touch
Lighting	LED 3 x 3W

Extraction performance	
Speeds	3
Airflow	700m ³ /h
Max noise level	69dB
Min noise level	48dB
Total wattage	259W
Grease filter	Stainless steel grid filter

Extraction options	
Ducting out	Requires ø 150mm ducting
Recycling	Charcoal filter included

Optional accessories	Code
Charcoal filter (re-order only)	HOOD-BE-AC-FI-LA
Remote control	HOOD-BE-AC-REM
Chimney kit	HOOD-BE-AC-CKITC

Further ducting and recycling information can be found on pages 54-57



Overside

Product	Code
Overside	HOOD-BE-OV-90-SS

Features
Perimeter extraction
LED technology
Advanced Sensor Control
Remote control - optional

Description	
Installation	Wall mounted
Size	900mm
Nett weight	19.5kg
Finish	Polished stainless steel
Controls	Electronic soft touch
Lighting	LED 3 x 3W

Extraction performance	
Speeds	3
Airflow	660m ³ /h
Max noise level	67dB
Min noise level	48dB
Total wattage	259W
Grease filter	Aluminium grid filter

Extraction options	
Ducting out	Requires ø 150mm ducting
Recycling	Charcoal filter included

Optional accessories	Code
Charcoal filter (re-order only)	HOOD-BE-AC-FI-LA
Remote control	HOOD-BE-AC-REM
Chimney kit	HOOD-BE-AC-CKITO

Further ducting and recycling information can be found on pages 54-57



Fusion

Product	Code
Fusion	HOOD-BE-FU-80-BL

Features
Perimeter extraction
Timer

Description	
Installation	Wall mounted
Size	800mm
Nett weight	26kg
Finish	Mirror glass and stainless steel
Control	Electronic soft touch
Lighting	Halogen 2 x 20W

Extraction performance	
Speeds	4
Airflow	675m ³ /h
Max noise level	66dB
Min noise level	46dB
Total wattage	290W
Grease filter	Aluminium grid filter

Extraction options	
Ducting out	Requires ø 150mm ducting
Recycling	Charcoal filter included

Optional accessories	Code
Charcoal filter (re-order only)	HOOD-BE-AC-FI-LA
Chimney kit	HOOD-BE-AC-CKITF

Further ducting and recycling information can be found on pages 54-57

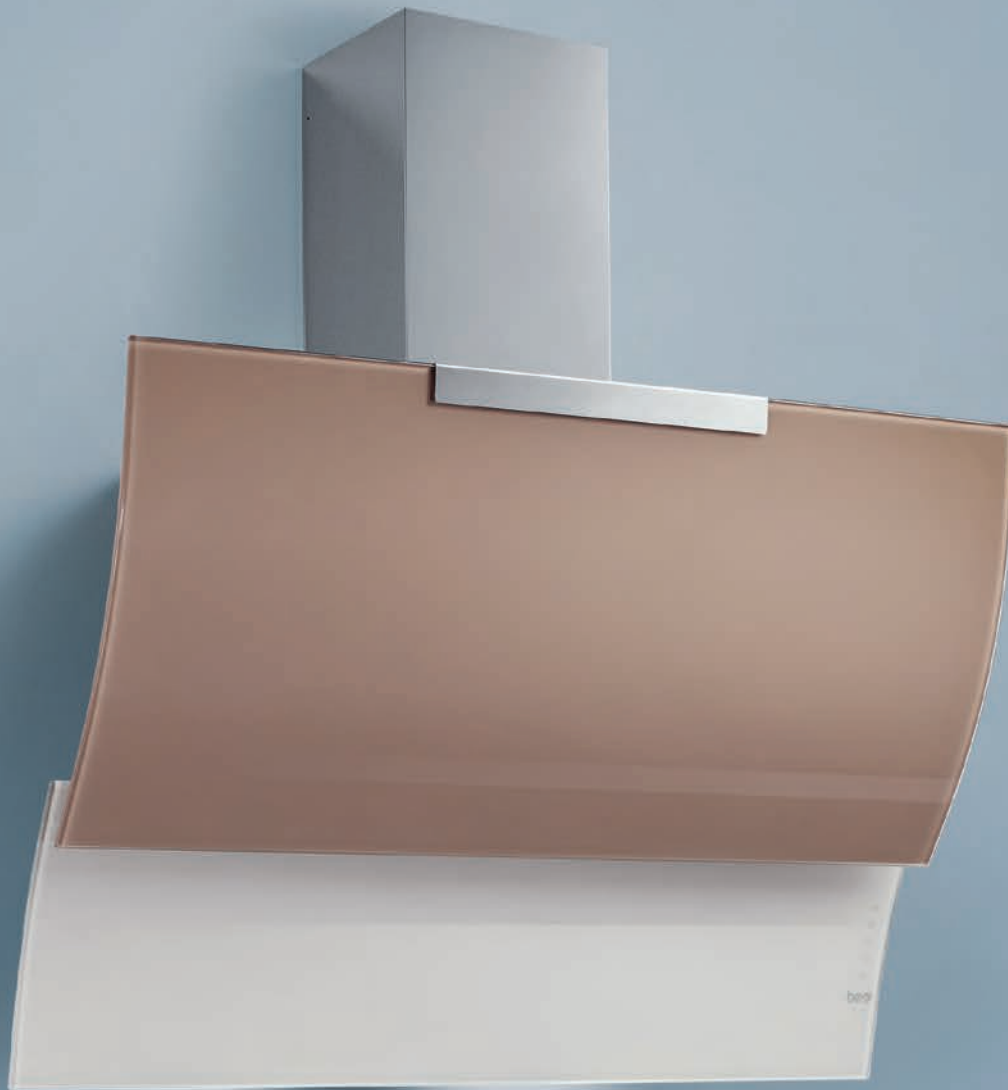

Fluttua black

Fluttua



Product	Code	Description	Extraction options
Fluttua black	HOOD-BE-FL-80-BL	Installation Wall mounted	Ducting out Requires ø 150mm ducting
Fluttua latte	HOOD-BE-FL-80-L	Size 800mm	Recycling Charcoal filter included
Features		Nett weight 25kg	Optional accessories
Perimeter extraction		Finish Polished stainless steel and glass	Code
LED technology		Control Electronic soft touch	Charcoal filter (re-order only) HOOD-BE-AC-FI-SF
Advanced Sensor Control		Lighting LED 2 x 2.5W	Remote control HOOD-BE-AC-REM
Remote control - optional		Extraction performance	Chimney kit HOOD-BE-AC-CKITL
Reversible motor		Speeds 3	
		Airflow 740m ³ /h	Further ducting and recycling information can be found on pages 54-57
		Max noise level 68dB	A space is required at the right hand side between the wall cupboard and the hood to operate the controls
		Min noise level 48dB	
		Total wattage 255W	
		Grease filter Aluminium grid filter	



Smooth black

Smooth

Product	Code
Smooth black	HOOD-BE-KE-55-BL
Smooth white	HOOD-BE-SM-80-WH

Features

Perimeter extraction
LED technology
Advanced Sensor Control
Remote control - optional
Reversible motor

Description	
Installation	Wall mounted
Size	800mm
Nett weight	25kg
Finish	Glass
Control	Electronic soft touch
Lighting	LED 2 x 2.5W and 1 x 3W

Extraction performance

Speeds	3
Airflow	700m ³ /h
Max noise level	67dB
Min noise level	48dB
Total wattage	255W
Grease filter	Aluminium grid filter

Extraction options

Ducting out	Requires ø 150mm ducting
Recycling	Charcoal filter included

Optional accessories

	Code
Charcoal filter (re-order only)	HOOD-BE-AC-FI-SF
Remote control	HOOD-BE-AC-REM
Chimney kit	HOOD-BE-AC-CKITL

Further ducting and recycling information can be found on pages 54-57

A space is required at the right hand side between the wall cupboard and the hood to operate the controls



Shelf

Product	Code
Shelf	
Stainless steel	HOOD-BE-SL-80-SS

Features
Timer

Description	
Installation	Wall mounted
Size	800mm
Nett weight	19.8kg
Finish	Stainless steel
Controls	Electronic slim
Lighting	Halogen 2 x 20W

Extraction performance	
Speeds	4
Airflow	715m ³ /h
Max noise level	67dB
Min noise level	48dB
Total wattage	290W
Grease filter	Stainless steel grid filter

Extraction options	
Ducting out	Requires ø 150mm ducting
Recycling	Requires charcoal filter

Optional accessories	Code
Charcoal filter (2 filters required)	HOOD-BE- AC-FI-SL

Further ducting and recycling information can be found on pages 54-57



Polar white

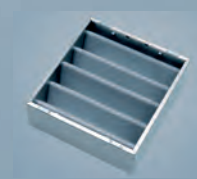

Wave filter

Polar



Product	Code
Polar black	HOOD-BE-PO-90-BL
Polar white	HOOD-BE-PO-90-WH

Features
BEST Silent Tech
Energy saving product
Perimeter extraction
Timer
Wave filter

Description	
Installation	Ceiling
Size	900 x 500mm
Nett weight	19.5kg
Finish	Stainless steel and glass
Controls	Electronic light touch
Lighting	Halogen 2 x 20W

Extraction performance	
Speeds	4
Airflow	800m ³ /h
Max noise level	60dB
Min noise level	41dB
Total wattage	240W
Grease filter	Aluminium grid filter

Extraction options	
Ducting out	Requires ø 150mm ducting
Recycling	Requires charcoal filter

Optional accessories	Code
Charcoal filter	HOOD-BE-AC-FI-PO

Further ducting and recycling information can be found on pages 54-57



Keys black

Keys

Product	Code
Keys black	HOOD-BE-KE-55-BL
Keys latte	HOOD-BE-KE-55-LA

Features
Perimeter extraction
LED technology
Advanced Sensor Control
Remote control - optional
Reversible motor

Description	
Installation	Wall mounted
Size	550mm
Nett weight	24.5kg
Finish	Polished stainless steel and glass
Control	Electronic soft touch
Lighting	LED 2 x 2.5W

Extraction performance	
Speeds	3
Airflow	700m ³ /h
Max noise level	67dB
Min noise level	48dB
Total wattage	255W
Grease filter	Aluminium grid filter

Extraction options	
Ducting out	Requires ø 150mm ducting
Recycling	Charcoal filter included

Optional accessories	Code
Charcoal filter (re-order only)	HOOD-BE-AC-FI-SF
Remote control	HOOD-BE-AC-REM
Chimney kit	HOOD-BE-AC-CKITL

Further ducting and recycling information can be found on pages 54-57

A space is required at the right hand side between the wall cupboard and the hood to operate the controls

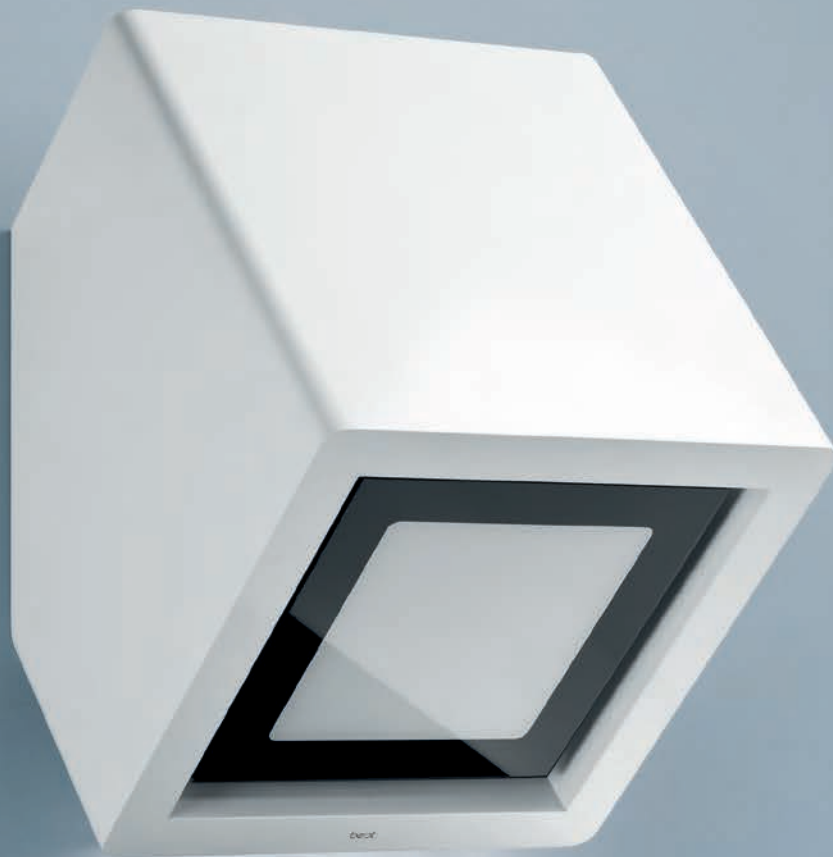

Kubi

Product	Code
Kubi	HOOD-BE-KU-50-WH

Features
Perimeter extraction
LED technology
Advanced Sensor Control
Remote control - optional
Reversible motor

Description	
Installation	Wall mounted
Size	500mm
Nett weight	26.5kg
Finish	Painted white and glass
Control	Electronic soft touch
Lighting	LED 3 x 3W

Extraction performance	
Speeds	3
Airflow	650m ³ /h
Max noise level	68dB
Min noise level	48dB
Total wattage	259W
Grease filter	Aluminium grid filter

Extraction options	
Ducting out	Requires ø 150mm ducting
Recycling	Charcoal filter included

Optional accessories	Code
Charcoal filter (re-order only)	HOOD-BE-AC-FI-LA
Remote control	HOOD-BE-AC-REM
No chimney kit available for this product	

Further ducting and recycling information can be found on pages 54-57

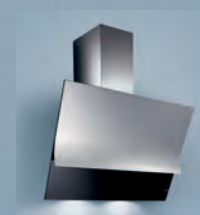

Surf with chimney kit

Surf

Product	Code
Surf black	HOOD-BE-SF-80-BL

Features

Perimeter extraction
Timer

Description	
Installation	Wall mounted
Size	800mm
Nett weight	25kg
Finish	Stainless steel and glass
Controls	Electronic soft touch
Lighting	Halogen 2 x 20W

Extraction performance

Speeds	4
Airflow	740m ³ /h
Max noise level	67dB
Min noise level	48dB
Total wattage	290W
Grease filter	Aluminium grid filter

Extraction options

Ducting out	Requires ø 150mm ducting and chimney kit
Recycling	Charcoal filter included

Optional accessories

	Code
Charcoal filter (re-order only)	HOOD-BE-AC-FI-SF
Chimney kit	HOOD-BE-AC-KITSF

Further ducting and recycling information can be found on pages 54-57

A space is required at the right hand side between the wall cupboard and the hood to operate the controls

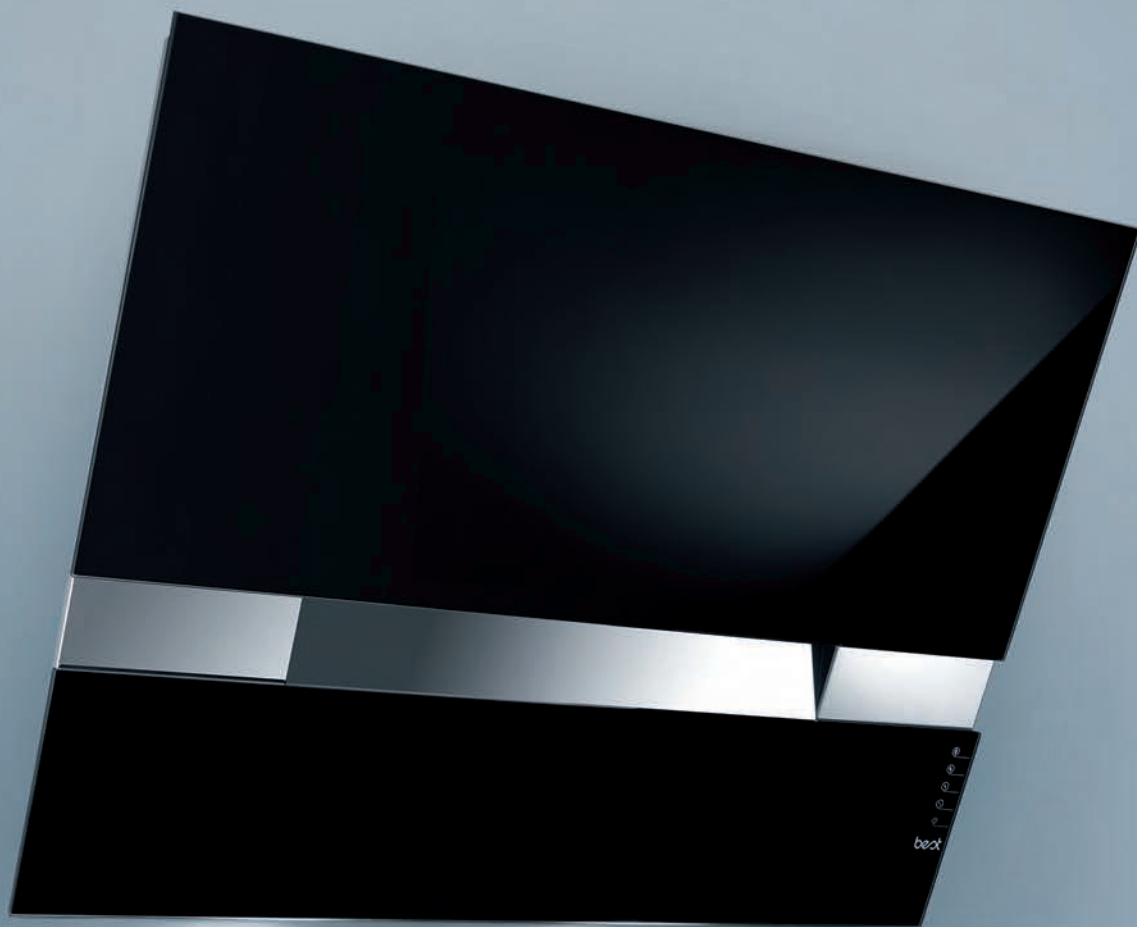

Kite white

Kite

Product	Code
Kite black	HOOD-BE-KT-80-BL
Kite white	HOOD-BE-KT-80-WH

Features

Perimeter extraction
Timer

Description	
Installation	Wall mounted
Size	800mm
Nett weight	25kg
Finish	Stainless steel and glass
Controls	Electronic soft touch
Lighting	Halogen 2 x 20W

Extraction performance

Speeds	4
Airflow	740m ³ /h
Max noise level	67dB
Min noise level	48dB
Total wattage	290W
Grease filter	Aluminium grid filter

Extraction options

Ducting out	Requires ø 150mm ducting and chimney kit
Recycling	Charcoal filter included

Optional accessories

	Code
Charcoal filter (re-order only)	HOOD-BE-AC-FI-SF
Chimney kit	HOOD-BE-AC-KITSF

Further ducting and recycling information can be found on pages 54-57

A space is required at the right hand side between the wall cupboard and the hood to operate the controls



Kite Small black

Kite Small

Product	Code
Kite Small black	HOOD-BE-KT-55-BL
Kite Small white	HOOD-BE-KT-55-WH

Features

Perimeter extraction
Timer

Description	
Installation	Wall mounted
Size	550mm
Nett weight	24.5kg
Finish	Stainless steel and glass
Controls	Electronic soft touch
Lighting	Halogen 2 x 20W

Extraction performance

Speeds	4
Airflow	740m ³ /h
Max noise level	67dB
Min noise level	48dB
Total wattage	290W
Grease filter	Aluminium grid filter

Extraction options

Ducting out	Requires ø 150mm ducting and chimney kit
Recycling	Charcoal filter included

Optional accessories

	Code
Charcoal filter (re-order only)	HOOD-BE-AC-FI-SF
Chimney kit	HOOD-BE-AC-KITSF

Further ducting and recycling information can be found on pages 54-57

A space is required at the right hand side between the wall cupboard and the hood to operate the controls



Etna

Product	Code
Etna Stainless steel	HOOD-BE-ET-90-SS

Features
Perimeter extraction Timer

Description
Installation Size Nett weight Finish Controls Lighting

Wall mounted
900mm
15.5kg
Stainless steel
Electronic slim
Halogen 2 x 20W

Extraction performance
Speeds Airflow Max noise level Min noise level Total wattage Grease filter

4
690m³/h
67dB
47dB
290W
Aluminium grid filter

Extraction options
Ducting out Recycling

Requires ø 150mm ducting
Requires charcoal filter

Optional accessories	Code
Charcoal filter	HOOD-BE-AC-FI2

Further ducting and recycling information can be found on pages 54-57



Latina

Product	Code
Latina	
Mirror glass	HOOD-BE-LA-90-SS

Features
Timer

Description	
Installation	Wall mounted
Size	900mm
Nett weight	15.5kg
Finish	Stainless steel and mirror glass
Controls	Electronic slim
Lighting	Halogen 2 x 20W

Extraction performance	
Speeds	4
Airflow	730m ³ /h
Max noise level	67dB
Min noise level	48dB
Total wattage	290W
Grease filter	Aluminium grid filter

Extraction options	
Ducting out	Requires ø 150mm ducting
Recycling	Requires charcoal filter

Optional accessories	Code
Charcoal filter	HOOD-BE-AC-FI-LA

Further ducting and recycling information can be found on pages 54-57



Cricket

Product	Code
Cricket	HOOD-BE-CR-90-WH

Features
Timer

Description
Installation
Size
Nett weight
Finish
Control
Lighting

Wall mounted
900mm

13kg

Polished stainless steel
and painted white

Electronic soft touch
Halogen 2 x 20W

Extraction performance

Speeds	4
Airflow	700m ³ /h
Max noise level	67dB
Min noise level	48dB
Total wattage	290W
Grease filter	Aluminium grid filter

Extraction options

Ducting out	Requires ø 150mm ducting
Recycling	Charcoal filter included

Optional accessories

Optional accessories	Code
Charcoal filter (re-order only)	HOOD-BE-AC-FI-LA

Further ducting and recycling information
can be found on pages 54-57



Nettuno 60cm/90cm

Product	Code
Nettuno 60cm	HOOD-UN-NE-60-SS
Nettuno 90cm	HOOD-UN-NE-90-SS

Features

Advanced Sensor Control
Timer

Description	
Installation	Wall mounted
Size	60cm or 90cm
Nett weight	17kg or 24kg
Finish	Stainless steel
Control	Electronic slim
Lighting	Halogen 2 x 20W

Extraction performance

Speeds	4
Airflow	700m ³ /h
Max noise level	68dB
Min noise level	50dB
Total wattage	290W
Grease filter	Aluminium grid filter

Extraction options

Ducting out	Requires ø 150mm ducting
Recycling	Requires charcoal filter

Optional accessories

	Code
Charcoal filter (re-order only)	HOOD-BE-AC-FI2

Further ducting and recycling information can be found on pages 54-57



Downdraft

For the ultimate combination of style and technology, a downdraft hood is certain to become a talking point in your kitchen. Neatly hidden away below the work surface when not in use; at the press of a button, BEST downdraft hoods rise ingeniously out of the counter to provide powerful and efficient extraction. The Lift enjoys features such as perimeter extraction, LED lighting, touch controls and attractive glass detailing; balancing effortless good looks with cutting-edge technology.

Lift

Product	Code
Motor included	
Lift 90cm	
Black glass	HOOD-BE-LI-90-GL
White glass	HOOD-BE-LI-90-WH
Stainless steel	HOOD-BE-LI-90-SS
Nett weight	18kg

Lift 60cm	
Black glass	HOOD-BE-LI-60-GL
White glass	HOOD-BE-LI-60-WH
Stainless steel	HOOD-BE-LI-60-SS
Nett weight	15.4kg

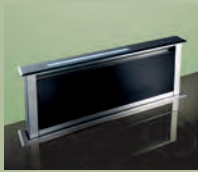

Lift black glass



Lift white glass

Product	Code
Motor not included	
Lift 90cm for external or remote motor	
Black glass	HOOD-BE-LE-90-GL
White glass	HOOD-BE-LE-90-WH
Stainless steel	HOOD-BE-LE-90-SS
Nett weight	21kg

Lift 60cm for external or remote motor	
Black glass	HOOD-BE-LE-60-GL
White glass	HOOD-BE-LE-60-WH
Stainless steel	HOOD-BE-LE-60-SS
Nett weight	17.5kg

Motors	
External motor	HOOD-BE-AC-EX-MO
Remote motor	HOOD-BE-AC-RE-MO

Features
 LED technology
 Perimeter extraction
 Remote control - optional

Description	
Installation	Downdraft
Size	600mm or 900mm
Finish	Stainless steel and glass
Controls	Touch control
Lighting	LED panel

Extraction performance	
Speeds	4
Airflow	800m ³ /h
Max noise level	69dB
Min noise level	51dB
Total wattage	260W
Grease filter	Aluminium grid filter

Extraction options	
Ducting out	Requires ø 150mm ducting
Recycling	Charcoal filter included
External or remote motor	Requires ø 150mm ducting

Optional accessories	Code
Charcoal filter (re-order only)	HOOD-BE-AC-FI-LT
Remote control	HOOD-BE-AC-REM
For roof adapter (external motor only)	HOOD-BE-AC-RF

Further ducting and recycling information can be found on pages 54-57

Further motor information can be found on page 57



Movie

Product Code

Motor included		
Movie 90cm		
Stainless steel	HOOD-BE-MO-90-SS	
Nett weight		17.5kg

Movie 60cm		
Stainless steel	HOOD-BE-MO-60-SS	
Nett weight		14.3kg

Motor not included		
Movie 90cm for external or remote motor		
Stainless steel	HOOD-BE-ME-90-SS	
Nett weight		21kg

Movie 60cm for external or remote motor		
Stainless steel	HOOD-BE-ME-60-SS	
Nett weight		17.5kg

Motors		
External motor	HOOD-BE-AC-EX-MO	
Remote motor	HOOD-BE-AC-RE-MO	

Features

Remote control - optional
Timer

Description

Installation	Downdraft
Size	600 or 900mm
Finish	Stainless steel
Controls	Electronic soft touch

Extraction performance

Speeds	4
Airflow	770m ³ /h
Max noise level	67dB
Min noise level	48dB
Total wattage	260W
Grease filter	Aluminium grid filter

Extraction options

Ducting out	Requires ø 150mm ducting
Recycling	Charcoal filter included
External or remote motor	Requires ø 150mm ducting

Optional accessories Code

Charcoal filter (Re-order only)	HOOD-BE-AC-FI-LT
Remote control	HOOD-BE-AC-REM
For roof adapter (external motor only)	HOOD-BE-AC-RF

Further ducting and recycling information can be found on page 54-57

Further motor information can be found on page 57



Essential reading before deciding on a cooker hood

You'll enjoy a cleaner kitchen with a ducted hood - as steam, vapour, smoke and odours are quickly and efficiently removed. Your home will benefit from this improved environment - free from the lingering fumes and smells associated with cooking. Every BEST chimney hood is ultra efficient. Superbly designed with modern living in mind - each of our high specification units is remarkably quiet during operation and BEST's renowned reliability comes as standard.

General

BEST hoods help remove cooking smells, vapours and condensation and are designed for quiet operation.

As a general rule the hood should be activated before cooking commences. You will mainly use the lower and mid speeds during normal cooking, resorting to maximum speed when dealing with emergencies - such as burning the toast! Maximum speed is sometimes necessary when using all burners or when griddling meat as this can create excessive vapours.

We publish against each model the noise levels for the maximum and minimum speeds to assist you when making comparisons with other makes.

The performance of a hood is extremely important and is normally measured in cubic metres per hour, i.e. how much air is moved. All BEST hoods have superior, powerful motors so it's well worth making comparisons before making your decision.

Correct airflow levels

Choosing the appropriate extraction power of the hood (airflow) generally depends on the size of the kitchen and the kind of cooking that takes place there.

The air capacity of a hood is expressed in cubic metres/hour (m³/h), and represents the quantity of air which the hood is able to extract at maximum speed, measured according to international standard IEC EN 61591.

To calculate the appropriate airflow level for your kitchen, multiply the volume of your kitchen by ten. For example:

if your kitchen is 3 metres wide, 5 metres long and 2.7 metres high, your calculation would be $(3 \times 5 \times 2.7) = 40.5 \times 10 = 405$.

This would mean a hood with an extraction of 400 m³/h or more will achieve efficient ventilation of the room.

If you often cook fish, fried foods, grilled meat or other dishes which produce a large quantity of smoke, grease and odours, we advise that you select a hood with an even greater air capacity. BEST offer a wide choice of hoods with air flow levels of up to 900m³/h.

Extraction

Ducting out or recycling?

It is always preferable to use BEST hoods as ducted models, i.e. ducted through an outside wall. Air is drawn into the hood, fats are trapped by the grease filter. Odours, fumes and condensation are then expelled to the outside.

On certain models you can choose to install the hood as a ducted model or a recycling model - we would only recommend that a hood is used as a recycling model if it is impossible to duct out. When using a hood as a recycling model, air is drawn into the hood and fats are trapped by the grease filter. The air then passes through charcoal filters to help absorb cooking odours and the purified air is recycled back into the kitchen.

It is realistic to assume that using a hood on recycling mode will circulate at least 30% less air than by ducting out - this is because the charcoal filters will restrict a certain amount of airflow. Charcoal filters are an optional extra unless otherwise indicated and will require replacing at least every 2/3 months or earlier with frequent use. Charcoal filters are not required if you duct out.

If a hood is used on recycling mode it will help reduce cooking odours but will not reduce steam or condensation. If you wish to reduce odours, steam and condensation, then you must duct out to expel these to the outside.

Height above hotplates - cooker hoods

Ideally the chimney hood should be positioned between 650mm to 750mm above the hotplate surface. Note that the chimney hood must not be positioned lower than 650mm.

On the Surf, Kite, Kite Small, Smooth, Fluttua and Keys the hood can be positioned as follows:

Electric hob - 400mm above hotplate

Gas hob - 500mm above hotplate

Please refer to the installation manuals for specific height recommendations.

Ducting

Try to plan your hood and cooker onto an outside wall in the kitchen if this is at all possible. By doing this, you will minimise the length of the ducting and maximise the hood performance. Hoods with reversible motors will not require a chimney kit if ducting out onto an exterior wall.

All BEST hoods have high extraction rates. Therefore, using the correct size ducting is of paramount importance.

The majority of BEST hoods have outlets which accept 150mm diameter. Do not be tempted to use reducers and fit 125mm or 100mm ducting as this will dramatically reduce performance and increase noise levels. Do not use concertina type expanding 150mm ducting.

When planning your ducting run try to keep the number of bends to a minimum as this will also help maximise the hood performance. We suggest that you always utilise Britannia rigid circular ducting or 'Mega duct' to optimise performance. Note ducting must not be connected to any existing ventilation or flue system that is being used for any other purpose.

Here are the maximum ducting lengths taking into account how many bends you require:

One 90° bend allows 4 metres of ducting
Two 90° bends allow 3 metres of ducting
Three 90° bends allow 2 metres of ducting

Ducted hood in the same room as a fossil fuel burning appliance

The following is a requirement of UK and European legislation and is in the interests of your safety.

If the room where a ducted cooker hood is to be installed also contains a fossil fuel burning appliance such as a gas or oil central heating boiler, then its flue must be of the room sealed or balanced flue type.

A ducted hood is not suitable for use in a room where any open flue is in use, as dangerous fumes of combustion can be sucked back into the room. This would include the following open flue appliances – central heating boilers, coal fires, log fires, gas fires, wood burning stoves, etc.

Therefore if you have an open flue fossil fuel burning appliance in your kitchen, you must select a hood that is capable of working on recycling mode.

Cooker hood – chimney kits

With the aid of the line drawings in the brochure and respecting the minimum distance between the cooker hotplate and underside of the hood, double check that everything will fit or ask your installer to check your sizes on your behalf. If you have any problems please contact the Britannia Technical Department who will be pleased to advise on all technical matters including coping with lower than average ceiling heights.

Island hood installations

When deciding on an island hood, there are several factors to take into consideration. Ensure that the ceiling is sound and that it has adequate strength to accept the weight of the hood. Also consider the route for the ducting and in which direction your ceiling joists run. It is not possible to run ducting in the opposite direction to the joists. Check the height of the joists as these are often 5" – so our Britannia Megaduct may be your ideal solution.

Canopy hood installations

These hoods are designed for fitting into the aperture of a canopy housing which can be of metal or cabinetry construction such as an over mantel arrangement. Sometimes a canopy hood is the ideal solution for positioning above a cooker that is sited in a disused chimney breast.

If you are having a canopy housing constructed, it will be beneficial to incorporate a catchment area into the underside of the housing – this would be a recess to hold and contain fumes, vapour, etc. before the canopy motor extracts these away.

If the underside of the canopy housing is totally flat, there is also a risk of fumes spilling around the front and/or sides of the canopy housing.

If the canopy housing is constructed in a combustible material it must be a minimum of 650 mm above the hotplate.

Guarantee

All BEST hoods are guaranteed for two years. Extended five year warranties are available. Your BEST stockist can give you full details. Please note that all guarantees and warranties relate to domestic installations only and not to commercial premises.



As the exclusive UK distributor, Britannia Living provides full support for all BEST products. This includes technical advice, delivery and after sales service.

Where to buy your BEST hood

To ensure you receive excellent service, Britannia has appointed BEST stockists throughout the UK mainland and Ireland.

Visit www.besthoods.co.uk or call 01253 471 111 to find your nearest stockist.

BEST appointed stockists are selected carefully and undergo thorough product training to ensure they have the required expertise and knowledge.

Technical advice

For any technical advice on installation and ducting please call the Britannia Technical Department directly on 0871 871 8680.

Delivery

Britannia employs its own dedicated delivery teams to ensure that BEST hoods get the care they deserve all the way from the factory to your kitchen. Please ask your stockist for details.

After sales service

A BEST hood will give you many years of satisfactory use.

A team of Britannia employed engineers is available throughout the UK mainland to look after your hood, should it unexpectedly require attention. Only Britannia engineers will be able to supply you with genuine parts, ensuring you will enjoy many years of continued use.

The Company reserves the right to alter any design or specification without notice. Every effort has been made to ensure an accurate colour representation. Due to the limitations of the printing process there may be some slight variations. Due to continual improvements, we may at any time modify the information present in this catalogue. All models that appear in this catalogue are patented. Errors and omissions excepted.

Hood ducting information

Hood fitted on an outside wall using 150mm diameter ducting

1 metre ducting kit – Duct 2609 comprises of:

- A** One metre pipe - Duct/1100-6
- B** 90° Bend - Duct/690
- C** Wall vent - Duct/6900

Always try to position your cooker and hood on an outside wall.

This makes for the easiest installation. It also minimises the ducting run length and maximises the hood's performance.

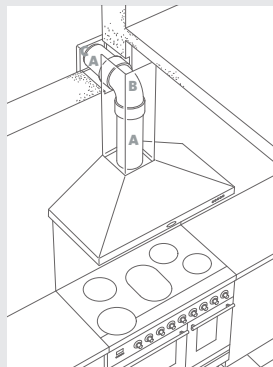

Hood fitted on an inside wall using 150mm diameter ducting

1 metre ducting kit – Duct 2609 comprises of:

- A** One metre pipe - Duct/1100-6
- B** 90° Bend - Duct/690
- C** Wall vent - Duct/6900

Ducting extras

- D** Pipe connection - Duct/693
- E** 1 metre pipe – Duct/1100-6 or 2 metre pipe – Duct/1200 - 6

Sometimes this is the ideal solution for kitchens with a false ceiling or for use in a bungalow. If being used in a house, check you have enough space. Check the direction of joists. Do not cut holes through joists.

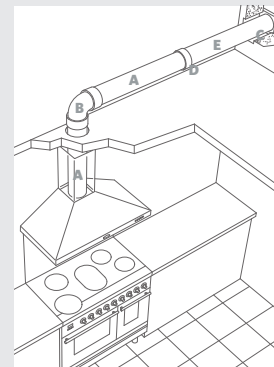

Hood fitted on an inside wall to run across top of units

Mega Duct kit – Duct 2652B comprises of:

- A** 150mm pipe (cut to size)
- B** Adjustable spigot 90° round* to rectangular bend
- C** 1 Metre flat of channel (can be cut to size)
- D** Flat channel connector
- E** Rectangular to round adaptor
- F** Wall plate
- G** Outside wall vent

*The 90° bend should be fitted outside and above the flue of the chimney board. Mega Duct can be boxed in to match kitchen and decorative flue sections.

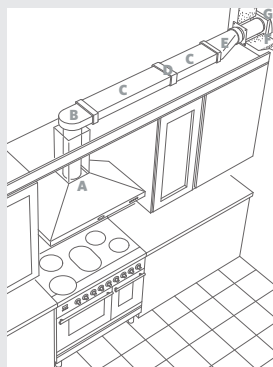

Hood fitted over an island unit using Mega Duct kit

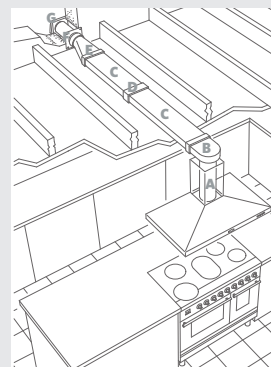

Mega Duct kit – Duct 2652B

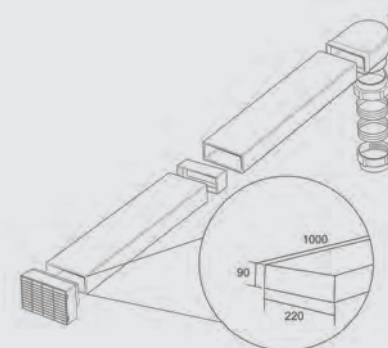

Product may vary from illustration shown.

To obtain the best possible extraction performance use 150mm diameter ducting. Wherever possible utilise rigid circular pipe or “Mega Duct” ducting – both types are available via your Britannia dealer. Do not use expanding concertina type ducting as this is not smooth on the interior and can cause air flow restrictions. Do not use ducting that has a smaller diameter than 150mm as this will reduce extraction rates and can increase noise levels. **Please note ducting kits and ducting components are optional accessories and have to be ordered – they are not supplied with the hood.**

Ducting extras

1 metre pipe 150mm diameter
Duct/1100-6

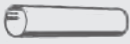

90° bend 150mm diameter
Duct/690



Wall vent with gravity flaps
Duct/6900



2 metre pipe 150mm diameter
Duct/1200-6



Horizontal bend
Duct/950



Pipe connector
Duct/693



1 metre and 2 metre pipes can
be cut to desired length

1 metre flat channel - Duct/910

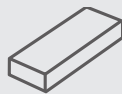

Flat channel connector
Duct/920



External and remote motors

	External	Remote
Product	EMD 950	CE 850 Q
Installation	External mounted	Internal mounted
Finish	Stainless steel	White
Airflow	850m ³ /h	740m ³ /h
Pressure	700Pa	460Pa
Max noise level	79dB	69dB
Total wattage	380W	320W
Outlet	ø Rectangular 200 x 215mm	ø 150mm
	External motor HOOD-BE-AC-EX-MO	Remote motor HOOD-BE-AC-RE-MO

External motor EMD 950 HOOD-BE-AC-EX-MO

For mounting outside the house

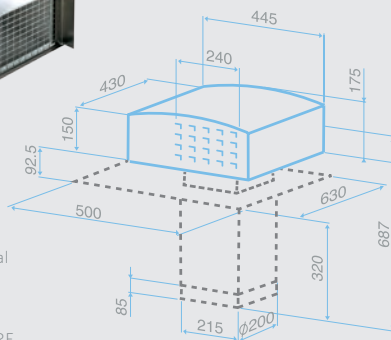
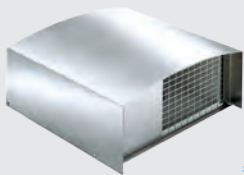

The dotted area represents the external motor accessory, which is required for roof installations.
Code HOOD-BE-AC-RF

Remote motor unit CE 850 Q HOOD-BE-AC-RE-MO

For mounting in another room or loft space

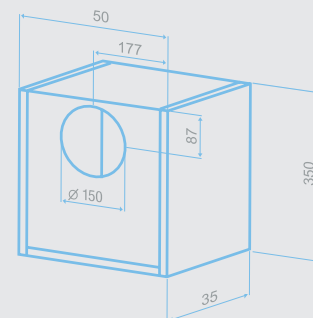

All products are eco - and RoHS compliant with the European Directive 2002/95/CE. We also support clear consumer information and the Code of Conduct promoted by CECEC. Brands supporting this code commit to supplying clear and accurate performance data on cooker hoods, measured according to common standards. In particular information regarding airflow and noise levels declared in this brochure complies with the European standards EN60704-2-13, EN60704-3, EN61591.

Ceilings

Enigma

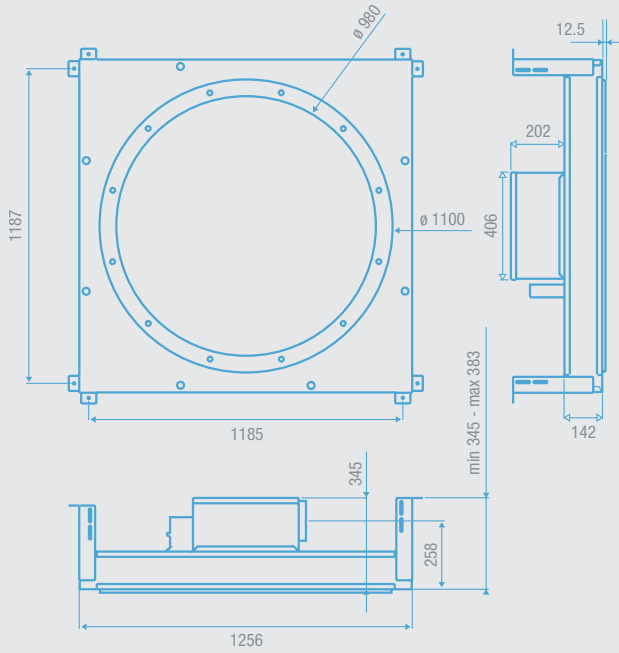

Cirrus Glass

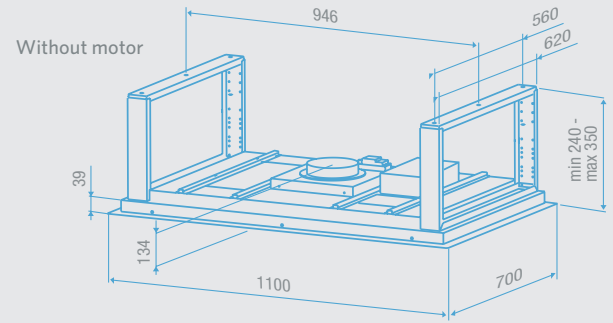
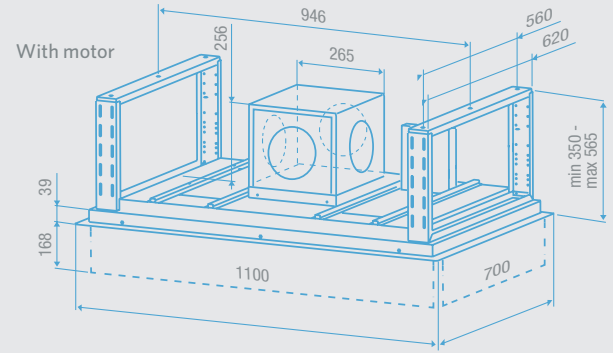

Cirrus

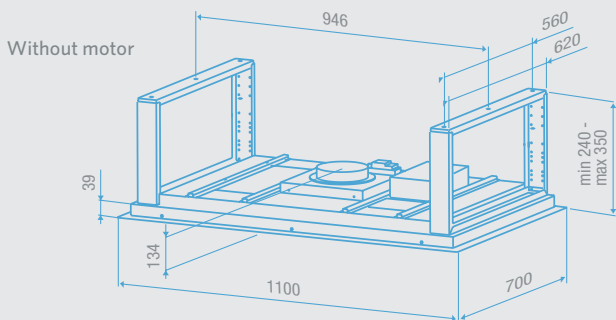
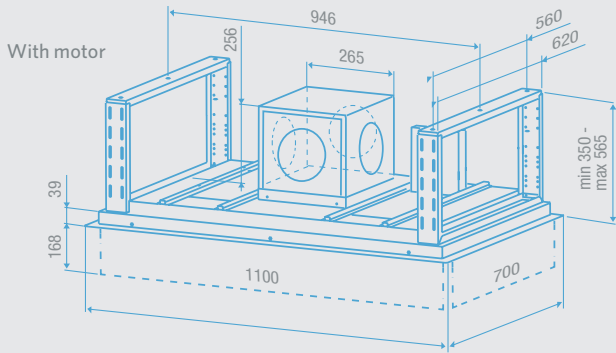

Visso - Canopy

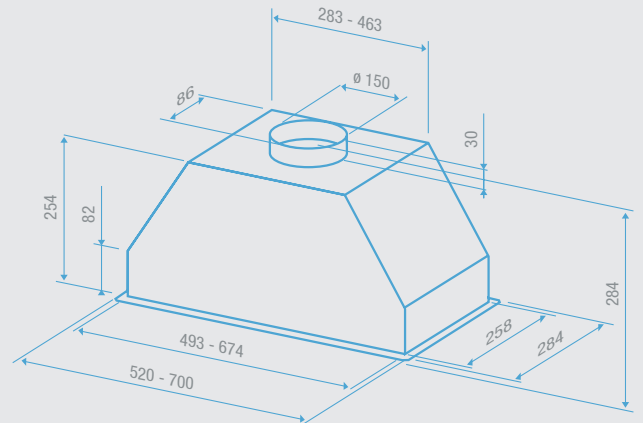

Ceilings - Pendants

Double Vertigo

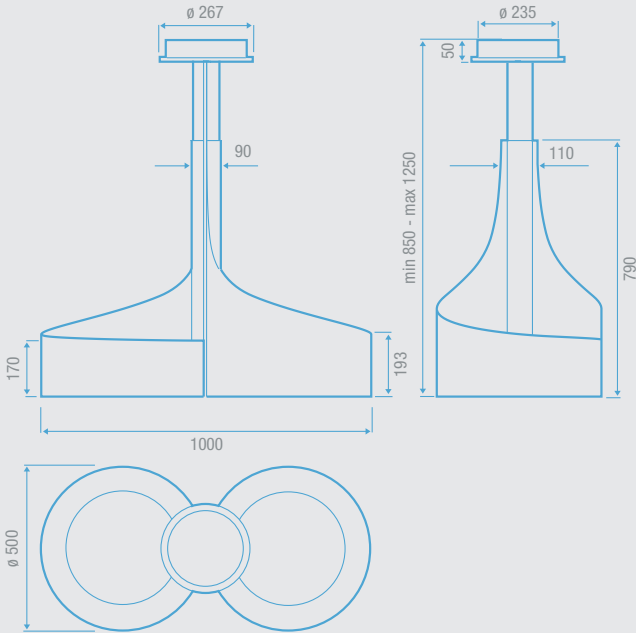

Sphera

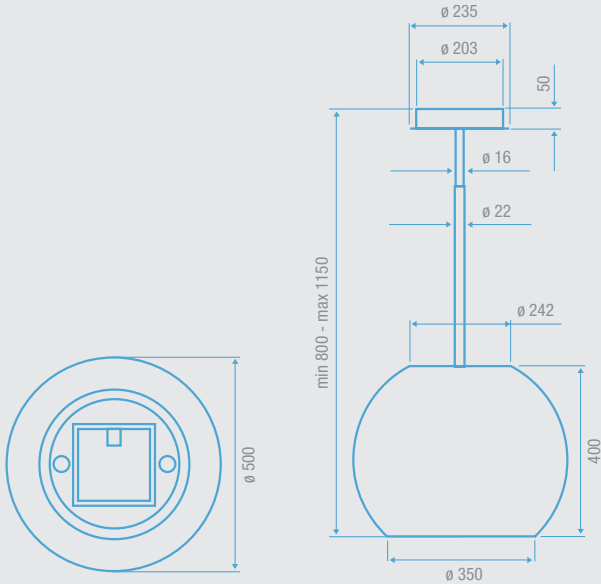

Vintage

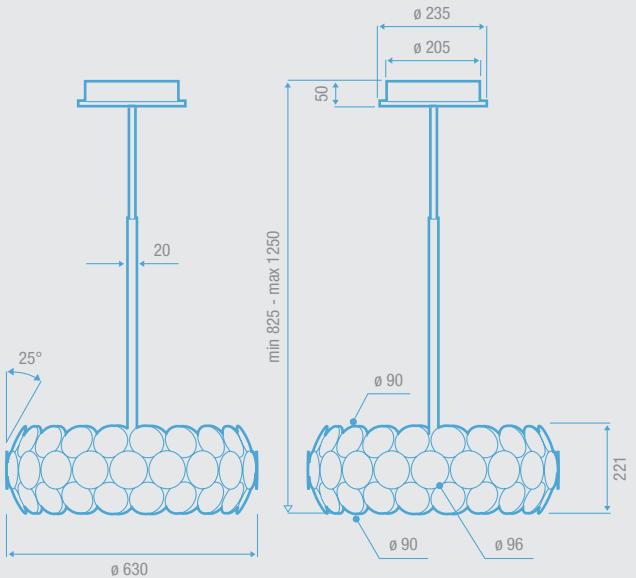

Outline

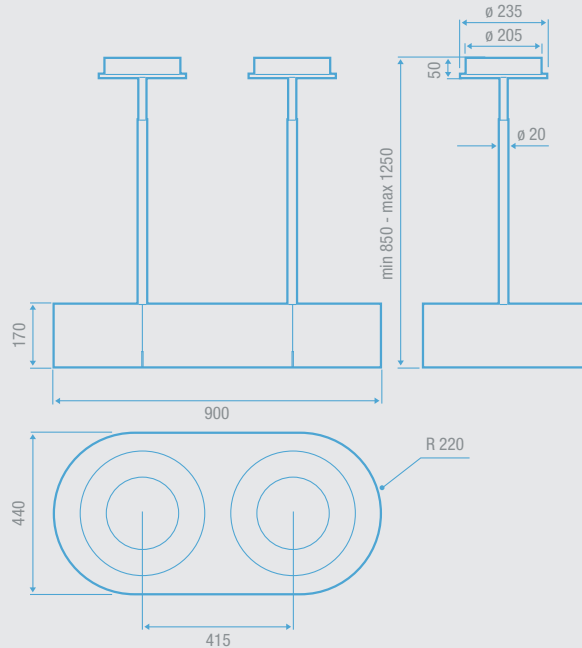

Ceilings - Pendants

Gemini

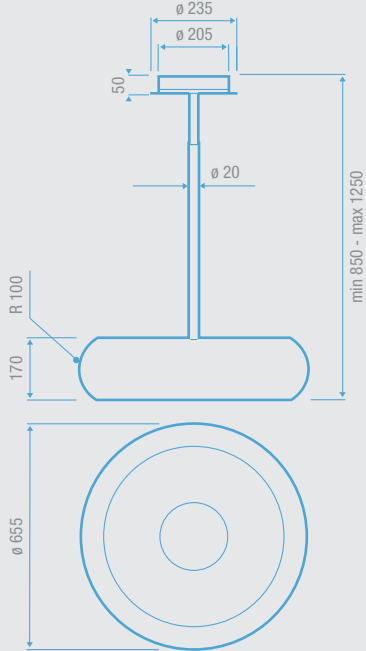

Moon

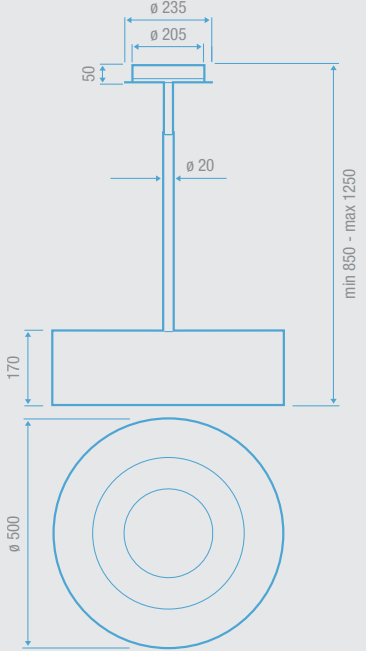

Cube

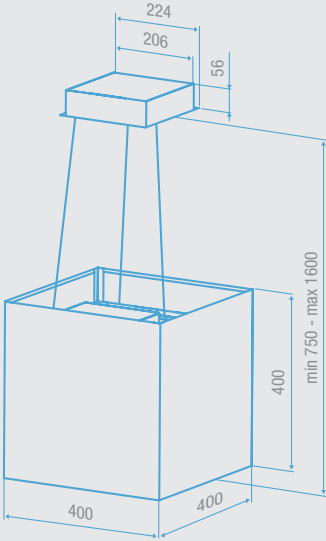

Ceilings - Islands

Collier Island

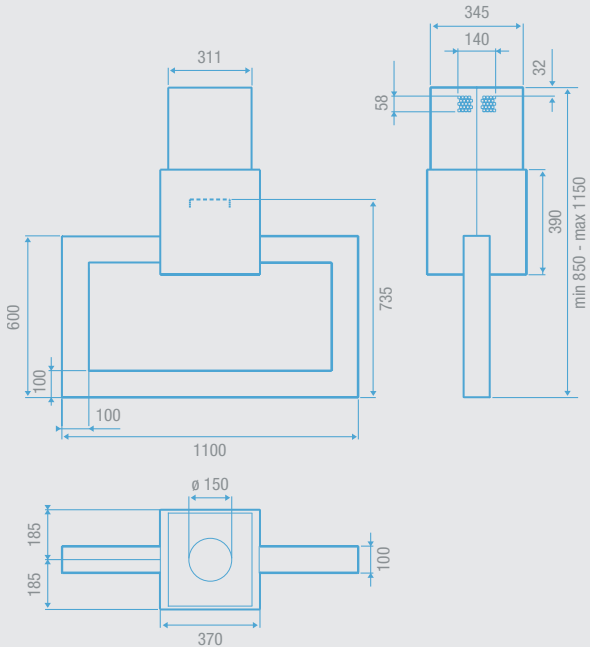

Fly

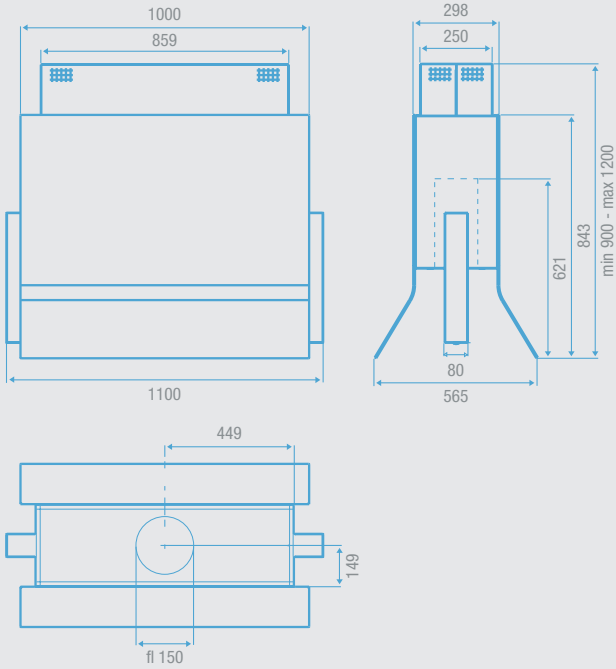

Polar Island

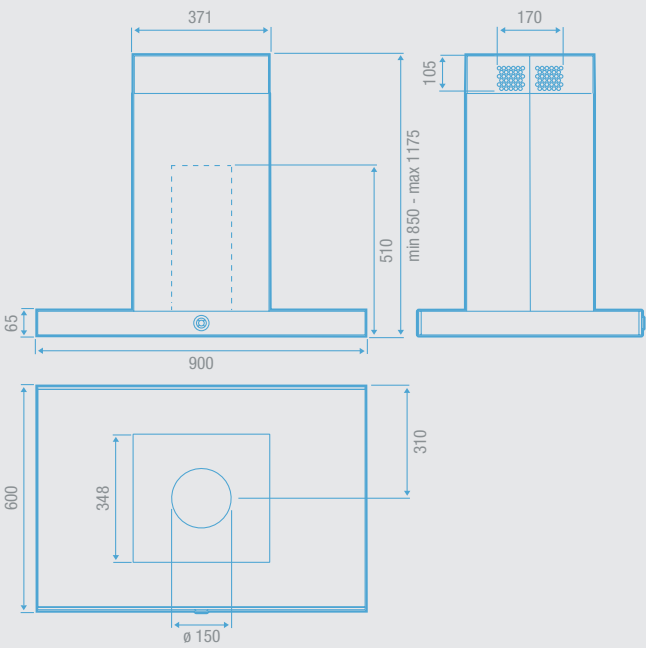

Spark

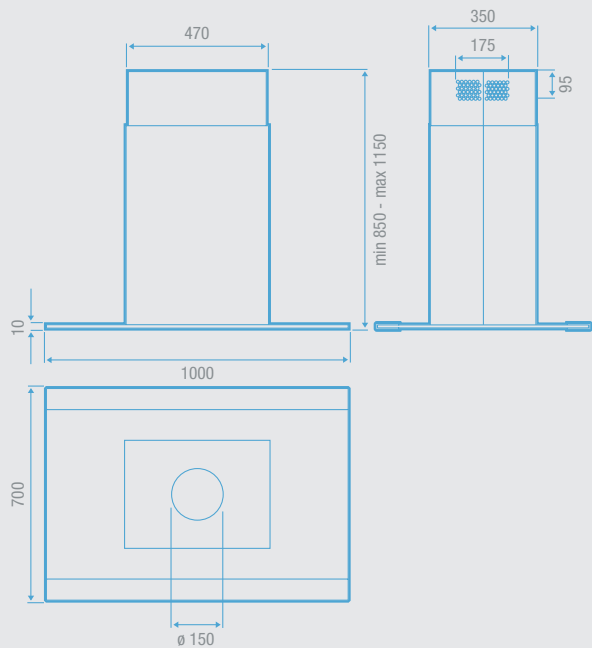

Ceilings - Islands

Lampedusa

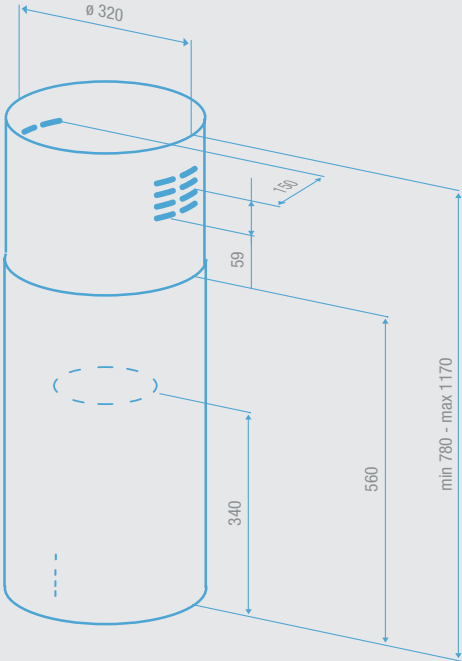

Wall mounted

Collier

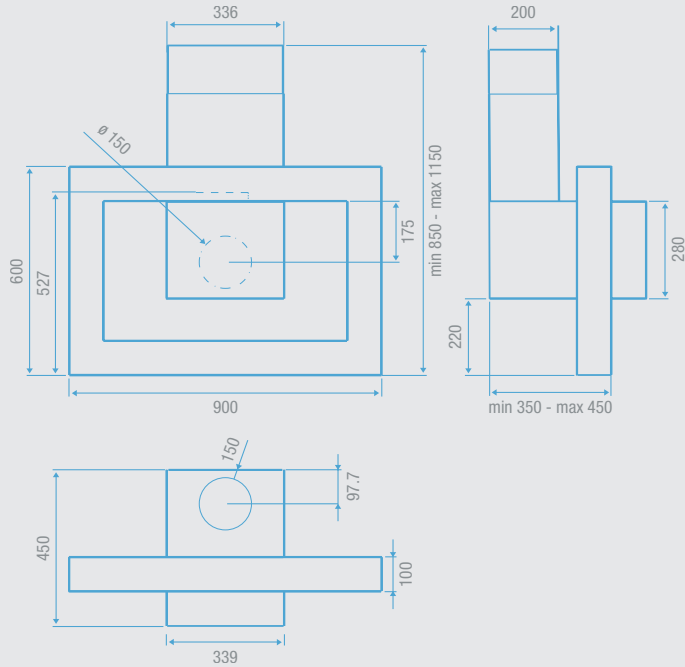

Overaside

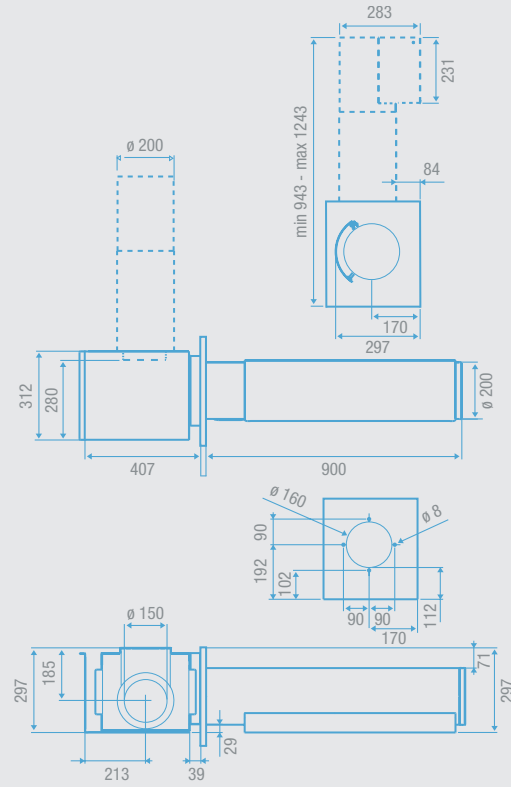

Fusion

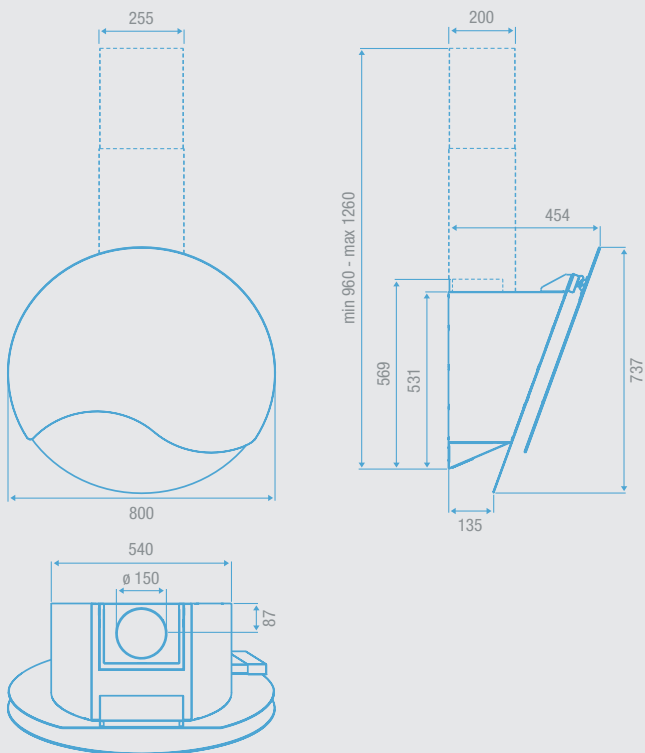

Fluttua

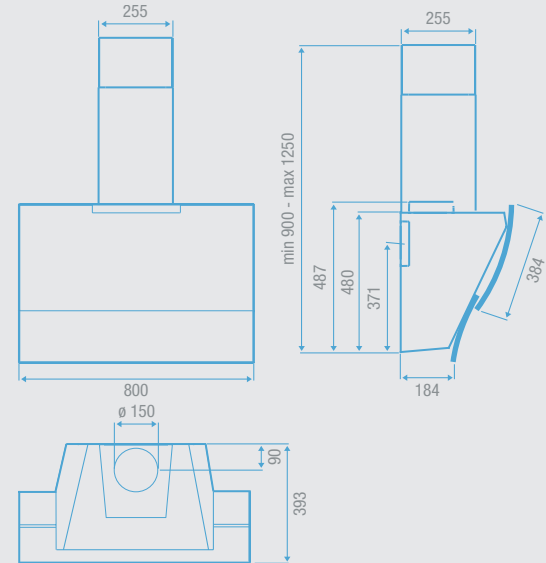

Wall mounted

Smooth

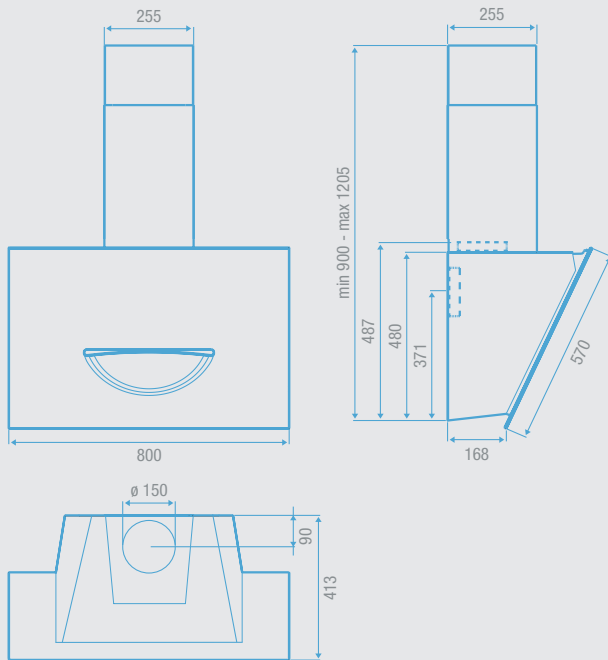

Shelf

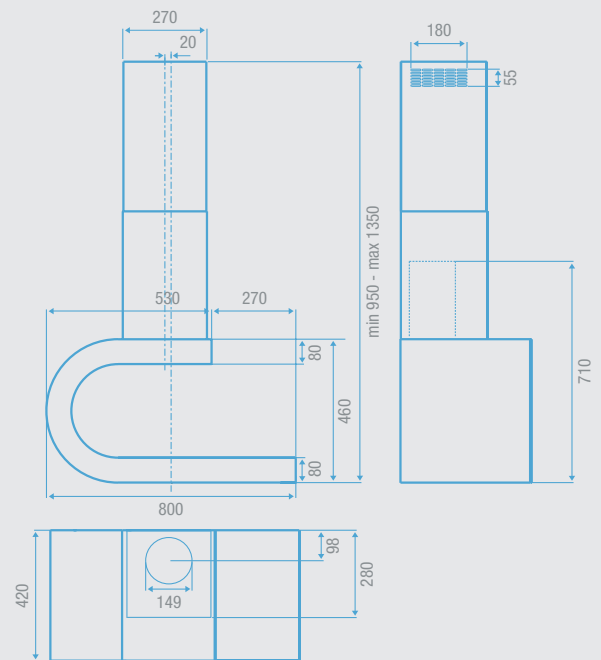

Polar

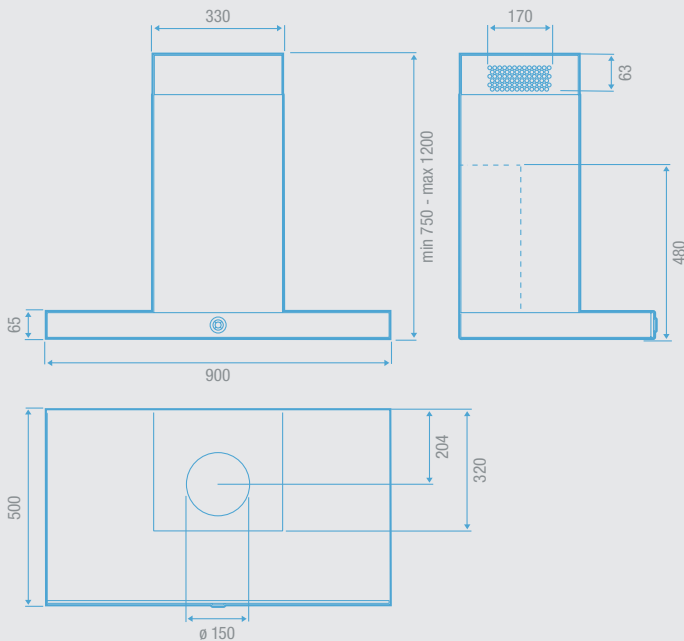

Keys

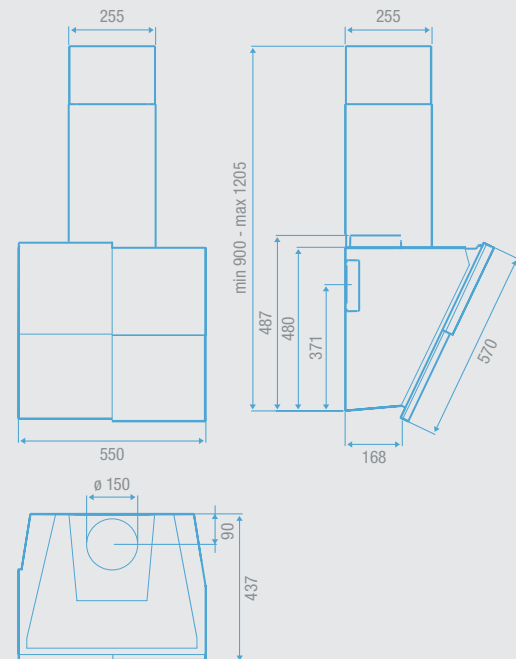

Wall mounted

Kubi

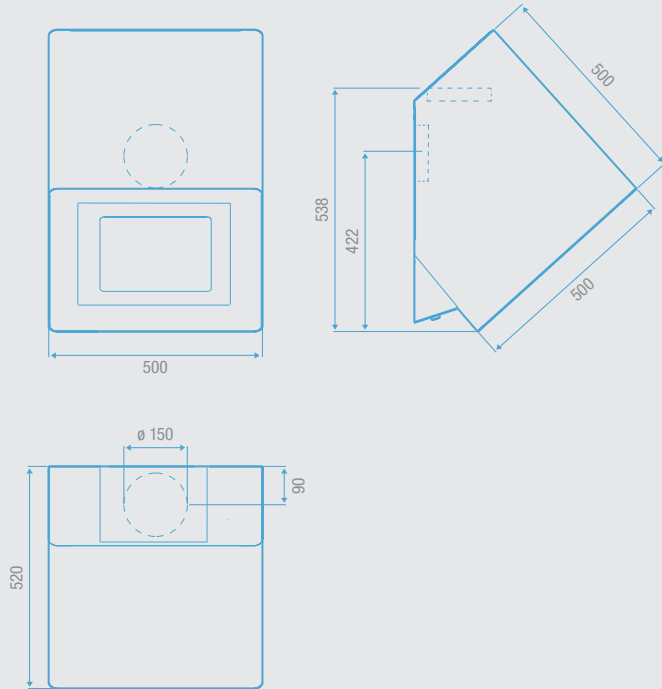

Surf

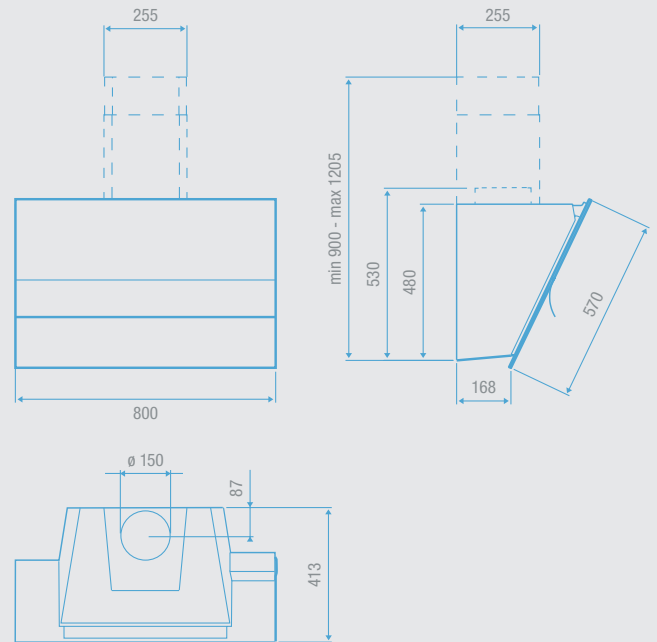

Kite

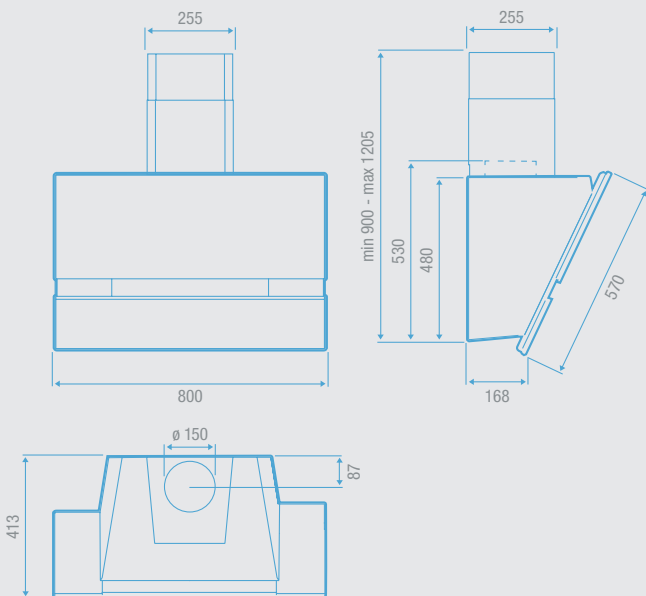

Kite Small

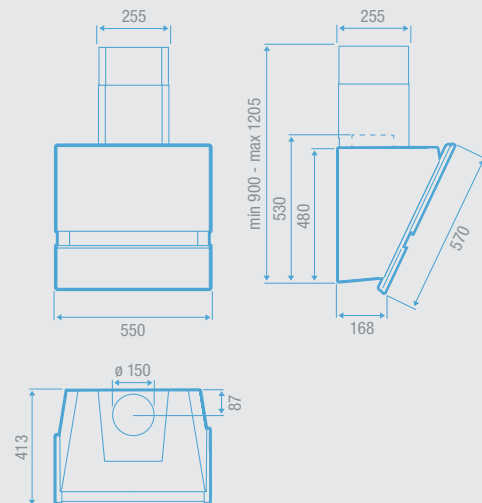

Wall mounted

Etna

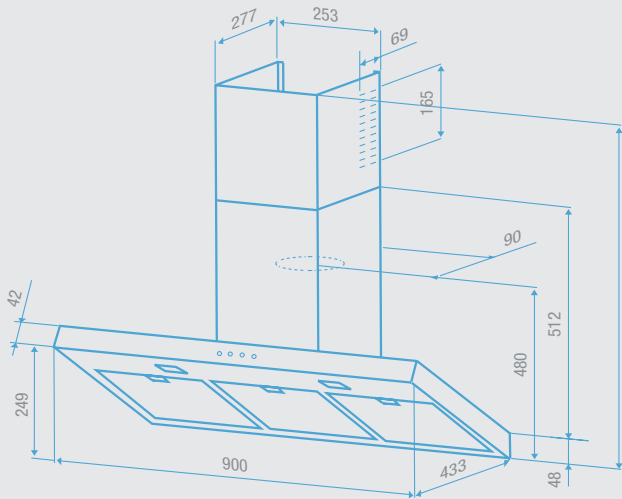

Latina

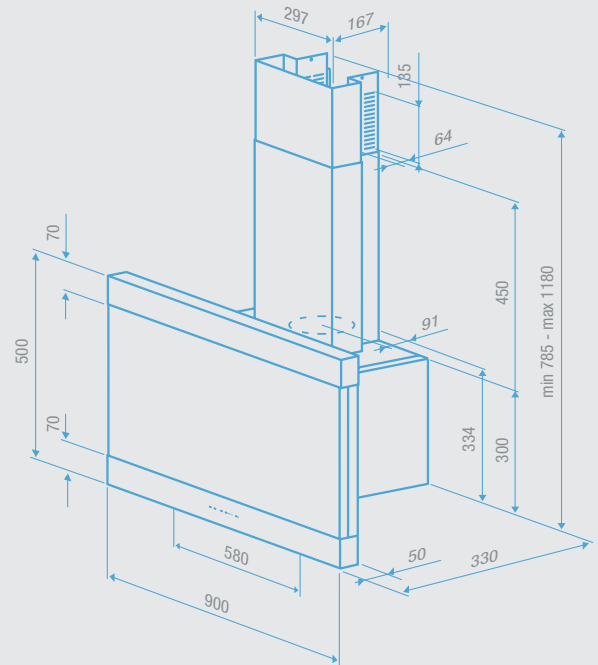

Cricket

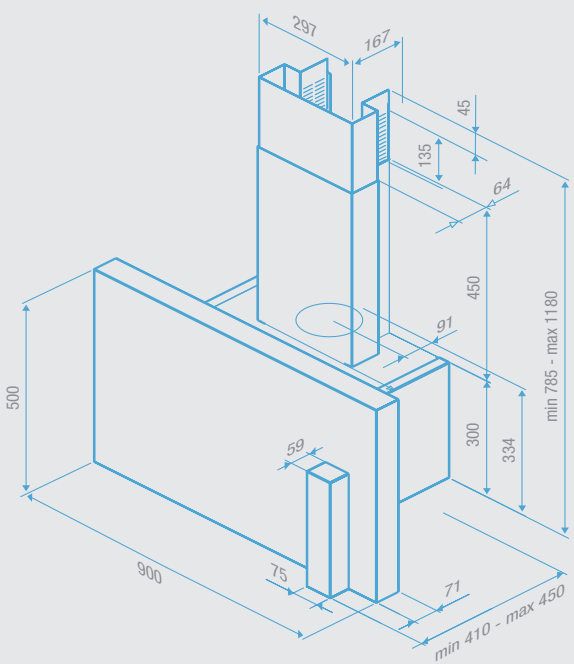

Nettuno

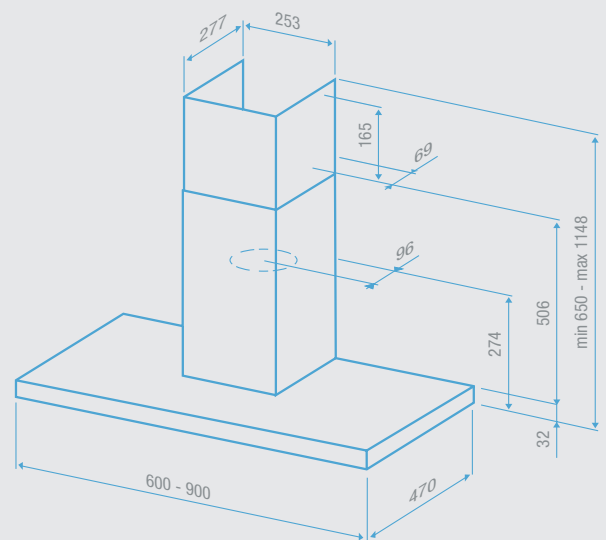

Downdraft

Lift

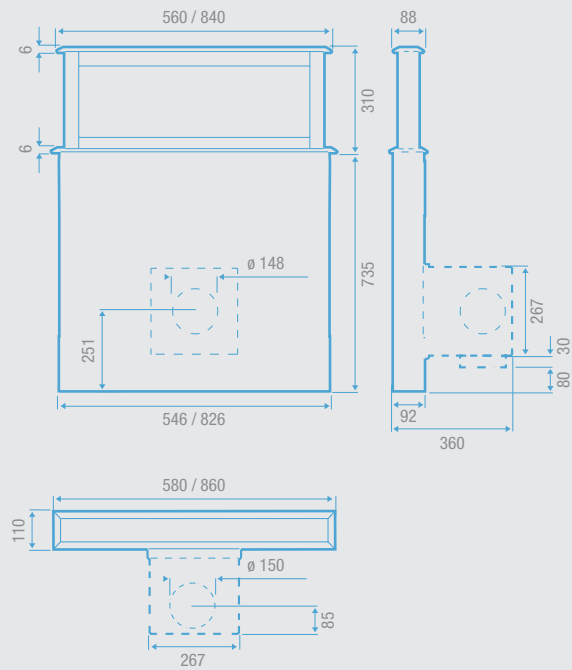

Movie

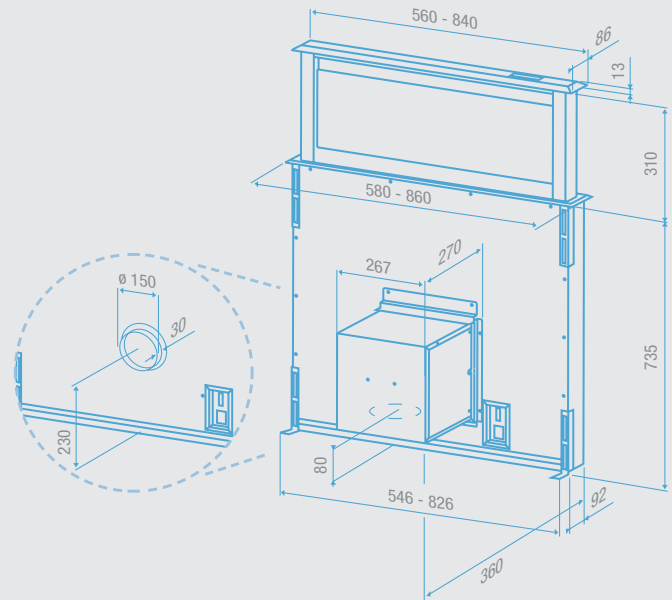



Britannia Living - a division of Glen Dimplex
Home Appliances, Eastern Rise, Trentham Lakes,
Stoke-on-Trent, Staffs, ST4 8WG
Call **01253 471 111**

best@britannialiving.co.uk
www.besthoods.co.uk



Distributed throughout Ireland by
Bodel Distributors Limited
N.I. Call **028 9267 2412**
R.O.I. Call **048 9267 2412**