

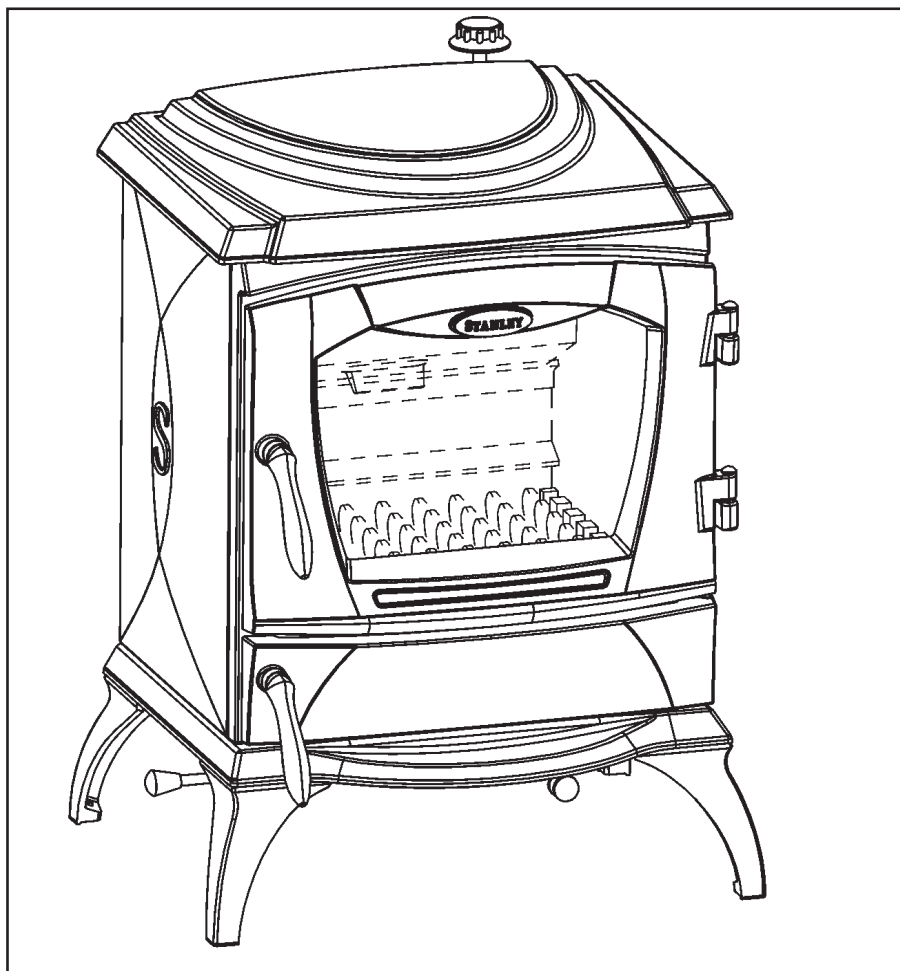

Lismore Boiler Solid Fuel Stove



INSTALLATION AND OPERATING INSTRUCTIONS

This appliance is hot while in operation and retains its heat for a long period of time after use. Children, aged or infirm persons should be supervised at all times and should not be allowed to touch the hot working surfaces while in use or until the appliance has thoroughly cooled.

When using the boiler stove in situations where children, aged and/or infirm persons are present a fire-guard must be used to prevent accidental contact with the stove. The fireguard should be manufactured in accordance with BS 8423:2002.

TABLE OF CONTENTS

| | PAGE NO. |
|--|-----------------|
| 1. General | 3 |
| Handling | 3 |
| Fire Cement | 3 |
| Asbestos | 3 |
| Metal Parts | 3 |
| 2. Electrical Connections | 3 |
| 3. Flues | 3 |
| 4. Flue Pipes | 4 |
| 5. Flue Exit - Top & Rear | 4 |
| 6. Chimney | 5 |
| 7. Ventilation & Combustion Air Requirements | 6 |
| 8. Permanent Air Vent | 6 |
| 9. External Ducted Air | 6 |
| 10. Heat Recovery Ventilation (HRV) | 7 |
| 11. CO Alarm | 7 |
| 12. Location | 7 |
| 13. Installation Clearances | 7 |
| 14. Floor Protection | 7 |
| 15. Flue & Water Pipe Locations | 8 |
| 16. Specification | 8 |
| 17. Technical Data | 9 |
| 18. Plumbing | 9 |
| 19. Regulations | 9 |
| 20. Gravity Circuit | 9 |
| 21. Injector Tee | 9 |
| 22. Water Circuit Temperature | 10 |
| 23. Pipe Thermostat | 10 |
| 24. Handover | 10 |
| 25. Important Notes | 11 |
| 26. Lighting | 12 |
| 27. Operating Instructions | 13 |
| 28. Recommended Fuels | 13 |
| 29. Thermostat Operation | 13 |
| 30. Secondary Air Control | 13 |
| 31. De-Ashing | 14 |
| 32. Disposal of Ashes | 14 |
| 33. To Clean Chimney Back Outlet | 14 |
| 34. Changing Grate Orientation | 15 |
| 34. Fire Safety | 15 |
| 35. Vitreous Enamel Cleaning | 16 |
| 36. Frozen System | 16 |

TABLE OF CONTENTS

| | PAGE NO. |
|-----------------------------------|-----------------|
| 37. Glass Cleaning | 16 |
| 38. Glass Replacement | 16 |
| 39. Summer Shutdown | 16 |
| 40. Exploded View | 17 |
| 41. Installation Check List | 18 |

THE LISMORE SOLID FUEL CENTRAL HEATING STOVE INSTALLATION & OPERATING INSTRUCTIONS

GENERAL

When installing, operating and maintaining your Lismore Stove respect basic standards of fire safety. Read these instructions carefully before commencing the installation. Failure to do so may result in damage to persons and property. Consult your local Municipal office and your insurance representative to determine what regulations are in force. Save these instructions for future reference.

Please note that it is a legal requirement under England & Wales Building Regulations that the installation of the stove is either carried out under Local Authority Building Control approval or is installed by a Competent Person registered with a Government approved Competent Persons Scheme. HETAS Ltd operate such a scheme and a listing of their Registered Competent Persons can be found on their website at www.hetas.co.uk.

Special care must be taken when installing the stove such that the requirements of the Health & Safety at Work Act are met.

Handling

Adequate facilities must be available for loading, unloading and site handling.

Fire Cement

Some types of fire cement are caustic and should not be allowed to come into contact with the skin. In case of contact with the skin wash immediately with plenty of water.

Asbestos

This stove contains no asbestos. If there is a possibility of disturbing any asbestos in the course of installation then please seek specialist guidance and use appropriate protective equipment.

Metal Parts

When installing or servicing this stove care should be taken to avoid the possibility of personal injury.

“IMPORTANT WARNING”

This stove must not be installed into a chimney that serves any other heating appliance.

| |
|---|
| <p>The complete installation must be done in accordance with current Standards and Local Codes. It should be noted that the requirements and these publications may be superseded during the life of this manual.</p> |
|---|

Please refer to the current standards, BS EN 15287-1:2007 Design, Installation and Commissioning of chimneys. BS EN 14336:2004: Heating Systems in Buildings. Installation & Commissioning of Water Based Heating Systems. BS EN 12828: 2003; Heating Systems in Buildings. Design of Water Based Heating Systems. BS EN 12831: 2003; Heating Systems in Buildings. method for calculation of the design heat load.

ELECTRICAL CONNECTIONS

The installation of any electrical services during the installation of this stove must be carried out by a registered competent electrician and in accordance with the requirements of the latest issue of BS 7671.

FLUES

Flues should be vertical wherever possible and where a bend is necessary, it should not make an angle of more than 45° with the vertical. Horizontal flue runs should be avoided except in the case of a back outlet from the appliance, when the length of the horizontal section should not exceed 150mm.

In order to minimise flue resistance and to make sweeping easier it is recommended to use 2 x 45° bends rather than a 90° bend.

The flue termination point must be located to minimise any wind effects. Wind effects of suction, pressure zones and turbulence can be created by the roof and adjacent objects. Wind effects can also be created by natural land contours.

To minimise the wind effects, the flue termination point should be located a minimum of 1000mm from the roof measured vertically and 2300mm measured horizontally. Where this termination point does not suffice it may be necessary to extend the flue pipe so that the termination point is above the apex. (See Fig.1)

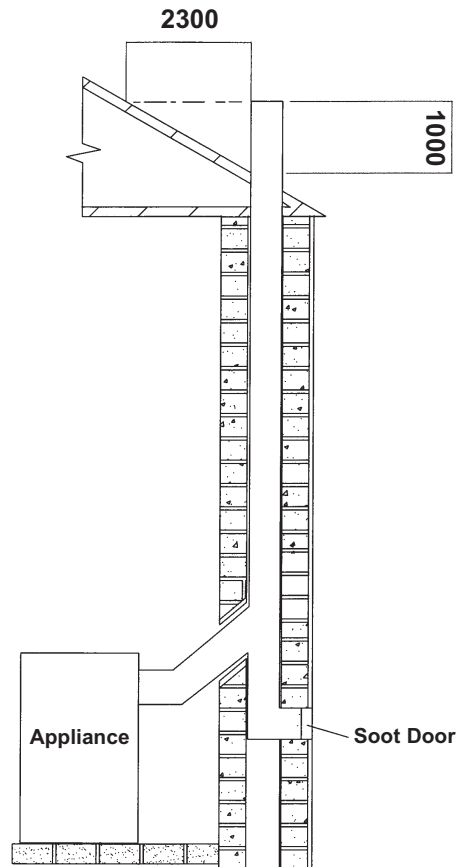

Fig.1

FLUE EXIT (TOP & REAR)

The stove is designed to allow the chimney be cleaned through the stove. If the chimney cannot be cleaned through the stove it is necessary to provide a soot box/access door in the flue for cleaning. See Fig.1A for recommended locations. Fit it to the stove as shown in Fig.2.

The stove is supplied with a reversible flue spigot for use with both top outlet and rear outlet. Fit the spigot as per Fig.2 for top outlet and as per Fig.3 for rear outlet.

Fig.1A

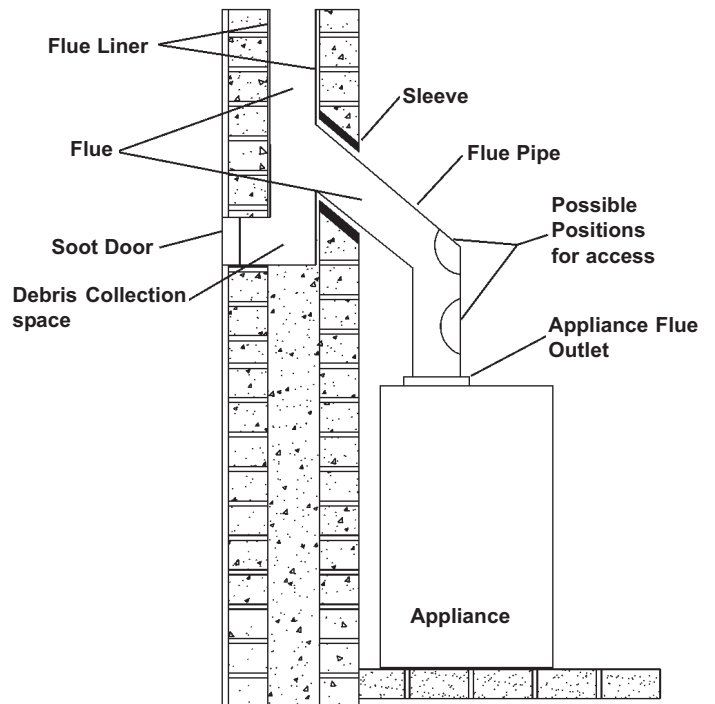
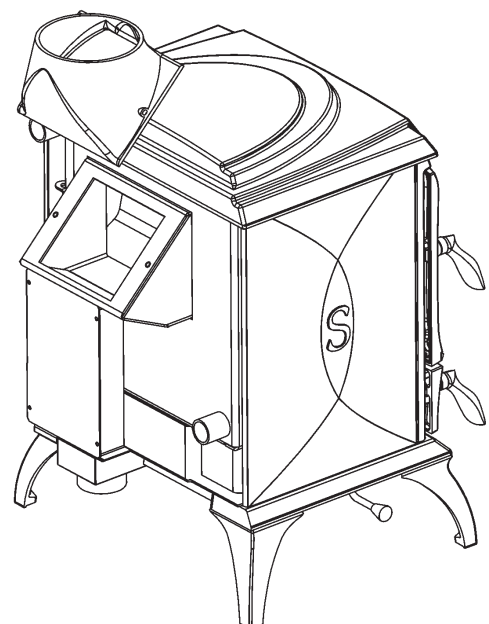

Fig.2



FLUE PIPES

A flue pipe should only be used to connect an appliance to a chimney and should not pass through any roof space.

Flue pipes may be of any of the following materials:

- * Cast iron as described in BS 41: 1973 (1981), or
- * Stainless steel with a wall thickness of at least 1mm and as described in BS EN 10095:1999 Specification for stainless and heat resisting steel plate, sheet and strip, for Grade 316 S11, 316 S13, 316 S16, 316 S31, 316 S33, or the equivalent Euronorm 88-71 designation, or
- * Vitreous enamelled steel complying with BS 6999: 1989.



Flue pipes with spigot and socket joints should be fitted with the socket uppermost.

Clearance to combustibles must be adhered to when fitting the flue pipe.

The appliance is suitable for intermittent operation on solid mineral fuel and intermittent operation on wood logs.

Fig.3

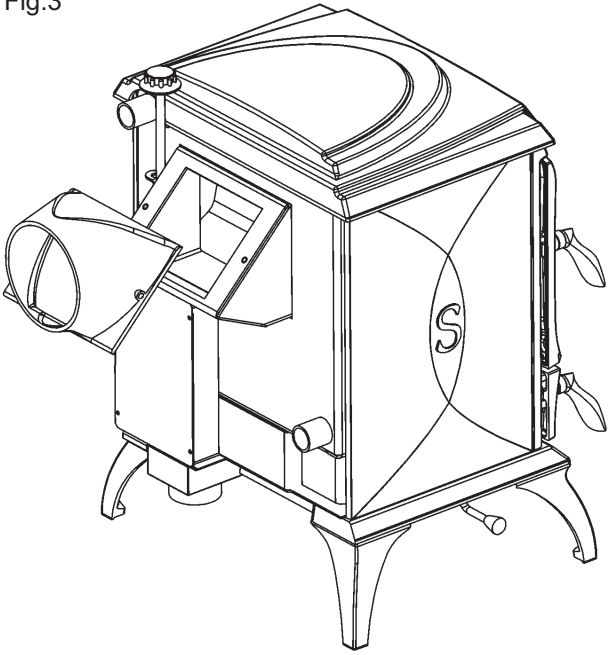

CHIMNEY

Do not connect to a chimney serving another appliance.

The stove is a radiant room heater and must be connected to a chimney of the proper size and type.

The chimney must have a cross-sectional area of at least 30 square inches 19350sq. mm or a diameter of at least 6" (150mm). It is best to connect to a chimney of the same size, as connection to a larger size may result in a somewhat less draught. Do not connect to a chimney serving another appliance. Minimum chimney height 15' (4.1 meters) from floor on which stove is installed. An existing masonry chimney should be inspected and if necessary repaired by a competent mason. The stove must be connected to a chimney with a minimum continuous draft of .06 wg. poor draft conditions will result in poor performance.

In adverse weather conditions, down drafts may be experienced causing smoke or fumes to spill into the room. If this occurs shut the appliance down by closing the air controls. If the problem persists seek the advice of a chimney sweep.

In order for the stove to perform satisfactorily the chimney height must be sufficient to ensure an adequate draught of approximately 12 Pa so as to clear the products of combustion and prevent smoke problems into the room.

NOTE: A chimney height of not less than 4.5 metres measured vertically from the outlet of the stove to the top of the chimney should be satisfactory.

Alternatively the calculation procedure given in EN 13384-1 may be used as the basis for deciding whether a particular chimney design will provide sufficient draught.

The outlet from the chimney should be above the roof of the building in accordance with the provisions of Building Regulations Approved Document J.

If installation is into an existing chimney then it must be sound and have no cracks or other faults which might allow fumes into the house. Older properties, especially, may have chimney faults or the cross section may be too large i.e. more than 230 mm x 230 mm. Remedial action should be taken, if required, seeking expert advice, if necessary. If it is found necessary to line the chimney then a flue liner suitable for solid fuel must be used in accordance with Building Regulations Approved Document J.

Any existing chimney must be clear of obstruction and have been swept clean immediately before installation of the stove. If the stove is fitted in place of an open fire then the chimney should be swept one month after installation to clear any soot falls which may have occurred due to the difference in combustion between the stove and the open fire.

If there is no existing chimney then any new system must be to the designation described above and in accordance with Building Regulations Approved Document J.

A single wall metal fluepipe is suitable for connecting the stove to the chimney but is not suitable for use as the complete chimney. The chimney and connecting flue must have a minimum diameter of 150mm and at no point must the diameter reduce to less than the size of the outlet socket of the stove.

Any bend in the chimney or connecting fluepipe should not exceed 45°. 90° bends should not be used.

Combustible material should not be located where the heat dissipating through the walls of fireplaces or flues could ignite it. Therefore when installing the stove in the presence of combustible materials due account must be taken of the guidance on the separation of combustible material given in Building Regulations Approved Document J and also in these stove instructions.

If it is found that there is excessive draught in the chimney then a draught stabiliser should be fitted. Fitting of a draught stabiliser will affect the requirement for the permanent air supply into the room in which the stove is fitted in accordance with

Approved Document J (see also combustion air supply).

Adequate provision e.g. easily accessible soot door or doors must be provided for sweeping the chimney and connecting fluepipe.

ALL FLUE INSTALLATIONS ARE THE RESPONSIBILITY OF THE CUSTOMER.

VENTILATION & COMBUSTION AIR REQUIREMENTS

It is imperative that there is sufficient air supply to the stove in order to support correct combustion. The air supply to this appliance must comply with current Building Regulations. The minimum effective air requirement for this appliance is 71.5cm². This increases to 110.5cm² where a flue draft stabiliser is fitted. If another appliance is fitted in an adjacent room it will be necessary to calculate an additional air supply.

All materials used in the manufacture of air vents should be such that the vent is dimensionally stable, corrosion resistant, and no provision for closure. The effective free area of any vent should be ascertained before installation. The effect of any grills should be allowed for when determining the effective free area of any vent.

Air vents direct to the outside of the building should be located so that any air current produced will not pass through normally occupied areas of the room.

An air vent outside the building should not be located less than the dimensions specified within the Building Regulations and B.S. 8303: Part 1 from any part of any flue terminal. These air vents must also be satisfactorily fire proofed as per Building Regulations and B.S. 8303: Part 1.

Air vents in internal walls should not communicate with bedrooms, bedsits, toilets, bathrooms or rooms containing a shower.

Air vents traversing cavity walls should include a continuous duct across the cavity. The duct should be installed in such a manner as not to impair the weather resistance of the cavity.

Joints between air vents and outside walls should be sealed to prevent the ingress of moisture. Existing air vents should be of the correct size and unobstructed for the appliance in use. If there is an extraction fan fitted in adjacent rooms where this appliance is fitted, additional air vents may be required to alleviate the possibility of spillage of products of combustion from the appliance/flue while the fan is in operation. Refer to B.S. 8303 Part 1.

Where such an installation exists, a test for spillage should be made with the fan or fans and other appliances using air in operation at full rate, (i.e. extraction fans, tumble dryers) with all external doors and windows closed.

If spillage occurs following the above operation, an additional air vent of sufficient size to prevent this occurrence should be installed.

Epecially Airtight Properties:-

If the stove is being fitted in a property where the design air permeability is less than 5m³ / (h.m²) (normally newer properties built from 2006), then a permanent ventilation must be fitted to provide 550mm² of ventilation for each kW of rated output. If a draught stabiliser is also fitted then the requirement is 850mm² per kW of rated output.

PERMANENT AIR VENT

The stove requires a permanent and adequate air supply in order for it to operate safely and efficiently. In accordance with current Building Regulations the installer will have fitted a permanent air supply vent into the room in which the stove is installed to provide combustion air. This air vent should not under any circumstances be shut off or sealed.

Extractor Fan

There must not be an extractor fan fitted in the same room as the stove as this can cause the stove to emit smoke and fumes into the room.

EXTERNAL DUCTED AIR

Where required the primary air supply can be ducted from outside. An aluminium flexible duct is available to order for connection to the stove.

It is recommended to bring the air supply for the stove into the house using a 4" plastic pipe. Where the pipe meets the outside wall make sure a vent cover is fitted properly to ensure no rodents can enter via the vent pipe.

The vent pipe should be located to prevent the ingress of moisture and in a location where it will not get blocked with leaves or any other debris. As wind effects can create suction and pressure zones of opposite sides of the dwelling it is recommended to run the air vent from opposite poles (North, South, East & West) of the dwelling and tee off for the air supply to the stove. This should negate the effect of suction and pressure zones. See Fig.4

Fig.4

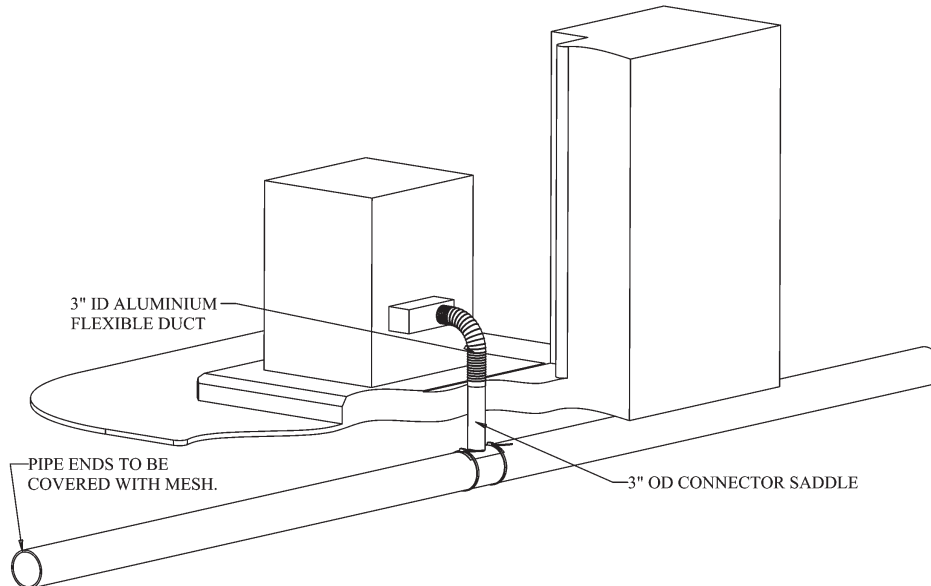

Note: When Installing outside air pipe adhere to 'Clearance to Combustible' Section.

HEAT RECOVERY VENTILATION

Where a stove is to be installed in a dwelling with *Heat Recovery Ventilation* (HRV) a number of precautionary measures must be undertaken:

Should for example the delivery fan in the HRV unit fail and the extraction fan in HRV fan continue to run the HRV may create a pressure less than atmospheric, this low pressure will effect the flue pressure which is required to safely evacuate the products of combustion from the stove.

1. Fit an adequately sized vent in the room to prevent pressure less than atmospheric occurring. The size should be established by closing all windows and doors and then creating the possible failure situation. Then open a window in the room where the stove is fitted, slowly until the pressure reaches atmospheric. The size of the window opening should be measured and a vent of the corresponding size installed.
2. Fit a CO Alarm which has been approved to EN 50291.

CO ALARM

Waterford Stanley recommend the fitting of a CO Alarm in the same room as the appliance, this is a requirement under UK Building Regulations. Further guidance on the installation of a carbon monoxide alarm is available in BS EN 50292:2002 and from the alarm manufacturers instructions.

Provision of an alarm must not be considered a substitute for either installing the appliance correctly or ensuring regular servicing and maintenance of the appliance and chimney system.

WARNING:-

If the CO Alarm sounds unexpectedly:-

1. **Open Doors and windows to ventilate the room and then leave the premises.**
2. **Let the fire go out.**

LOCATION

There are several conditions to be considered in selecting a location for your Stanley Lismore Stove.

- a. Position in the area to be heated, central locations are usually best.
- b. Allowances for proper clearances to combustibles.

INSTALLATION CLEARANCES

Maintain at least the following clearances to all combustible material:

| | |
|--------------------|----------------------------------|
| From the front | 460 mm (18") |
| From the back | 280 mm (11") |
| From the sides | 100 mm (4") |
| From the flue pipe | 460 mm (18") straight up only |

Brick wall minimum clearance, but allow access for controls and water fittings.

FLOOR PROTECTION

It is recommended that this appliance is installed on a solid, level, non combustible hearth conforming to current Building Regulations.

It is recommended that a minimum clearance of 100mm be maintained from the sides and rear of the appliance to a tiled fireplace or masonry wall, especially on the right of the appliance as access is required for the controls. See Fig.5.

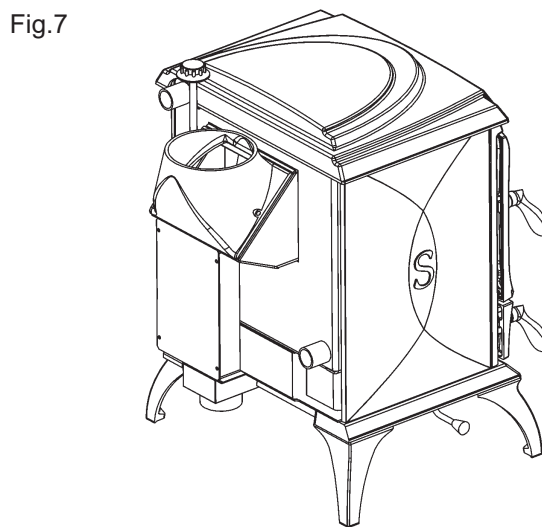
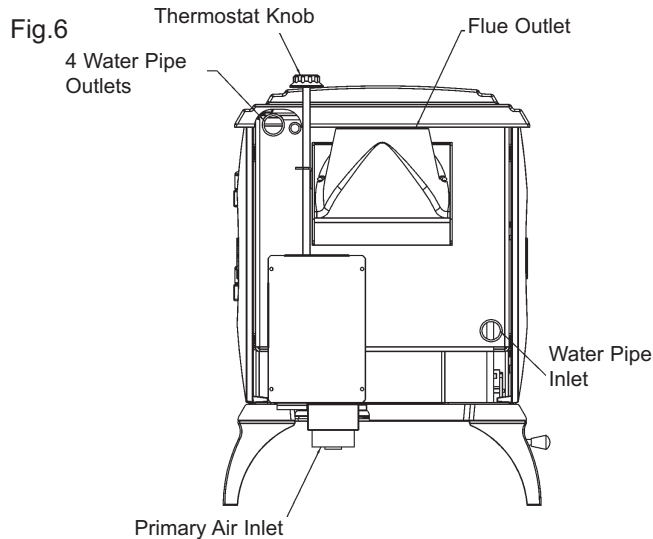
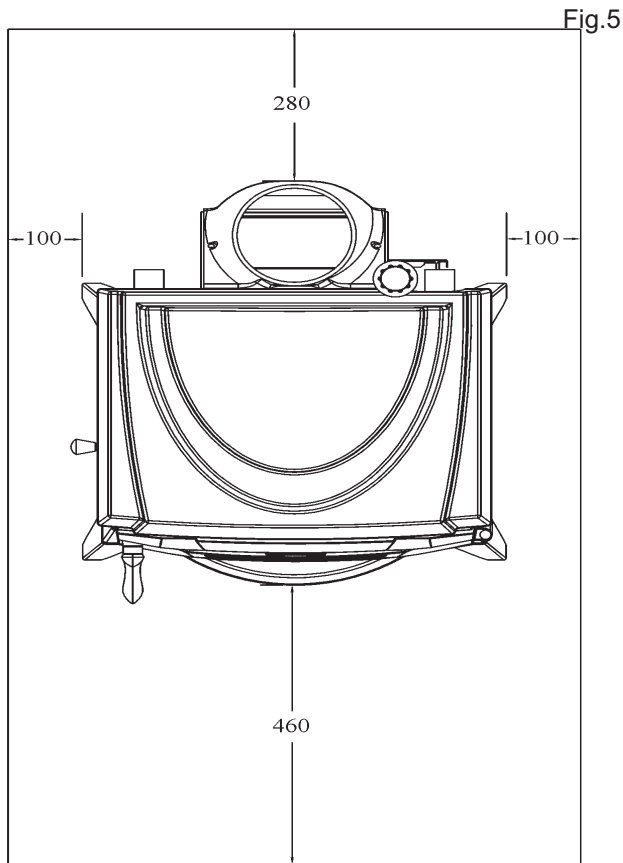

FLUE & WATER PIPE LOCATIONS

Flue outlet to suit 152mm (6") internal diameter flue pipe.

Water outlets 25mm (1") B.S.P.

TECHNICAL DATA

| | MANUFACTURED SMOKELESS FUEL | | | WOOD | | |
|---|-----------------------------|---------|-------|--------------|-------|-------|
| | Room | Water | Total | Room | Water | Total |
| Max: (kW) | 5.1 kW | 12.1 kW | 17.2 | 3 kW | 8 kW | 11 |
| Nominal: (kW) | 5.1kW | 12.1kW | 17.2 | 2.4 kW | 5.5kW | 7.9 |
| Typical refuelling intervals to obtain nominal outputs: | MSF 2 hours | | | WOOD .77 hrs | | |
| Flue Gas Mass Flow: | MSF 8.9 g/s | | | WOOD 8.5 g/s | | |
| Flue Gas Mass at nominal output: | 414°C | | | 274°C | | |
| Gross Weight: | 200 kgs | | | | | |
| Flue Outlet: | 150mm | | | | | |
| Flue Draught: | 12 Pa | | | | | |
| Boiler Tappings: | 1" BSP | | | | | |
| Max Water Pressure: | 2 Bar | | | | | |
| Efficiency: | 76.8 % | | | 74.7 | | |

WARNING: DO NOT OBSTRUCT PRIMARY AIR SUPPLY TO THE AIR DUCT AT THE RIGHT HAND SIDE OF THE STOVE

SPECIFICATION

Fig.8

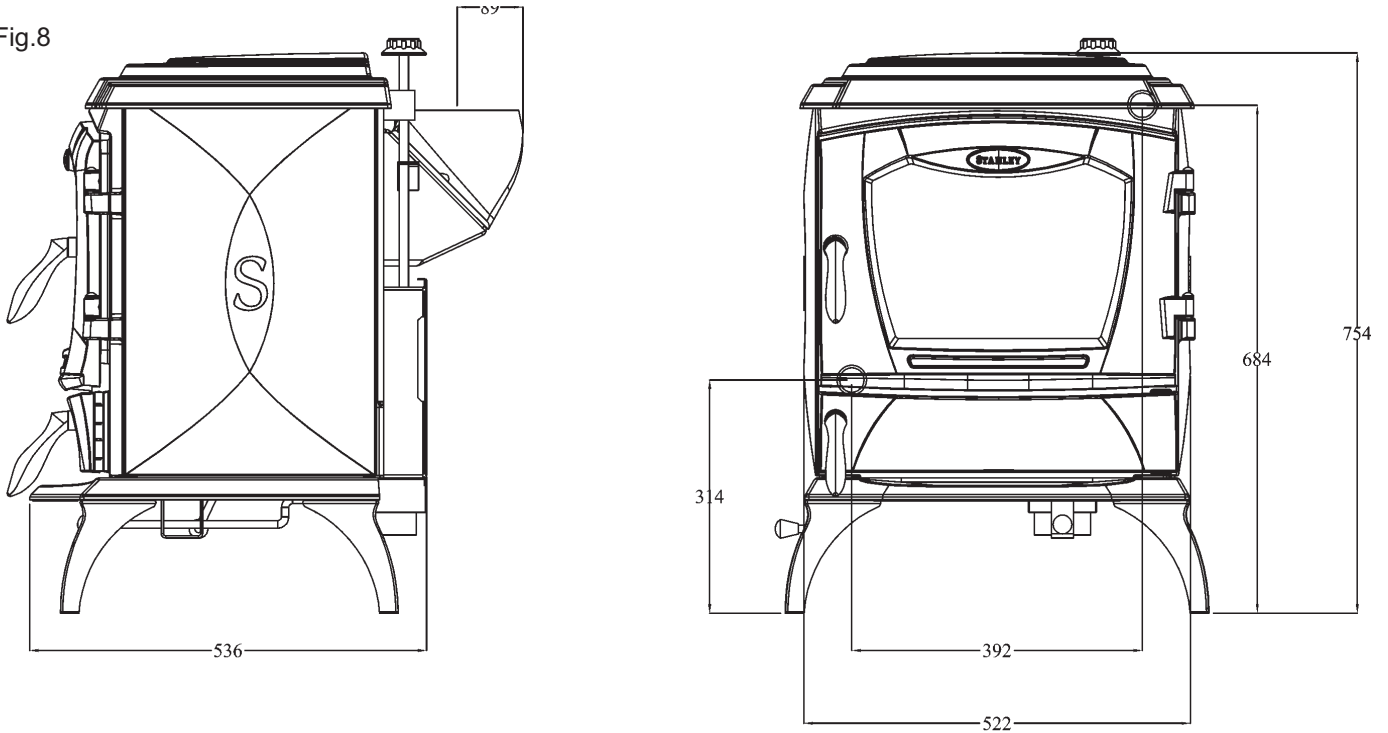
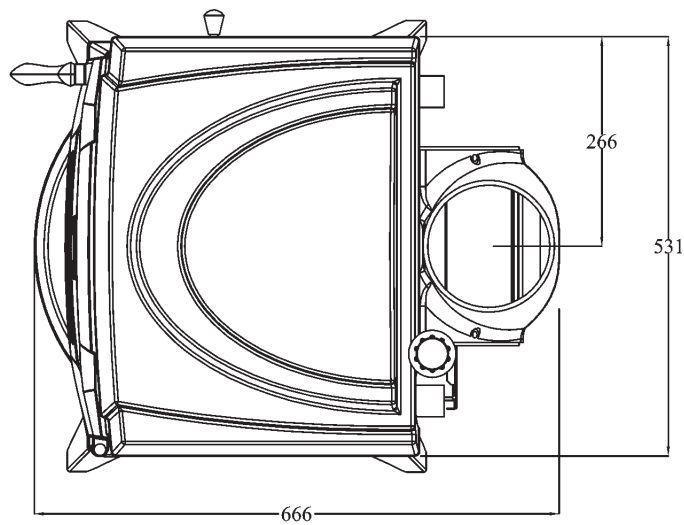

Fig.8a



Note: Dimensions stated are in millimetres unless otherwise stated and may be subject to a slight +/- variation.

PLUMBING

REGULATIONS

The plumbing must be in accordance with all relevant regulations and practices. It must include a gravity circuit with expansion pipe, open to the atmosphere. The central heating will normally be pump-driven as with other types of boilers.

GRAVITY CIRCUIT

The gravity circuit consists of the domestic hot water tank of 135 litres indirect cylinder, fixed in an upright position, recommended for hot water storage and it should be connected to the boiler by 28mm diameter flow and return piping. The pipes should not exceed 7.8 meters (25ft) in length and cylinder and pipework should be fully lagged. The shorter the run of pipe work the more effective the water heating.

There must be no gate valves on this circuit and it must have an expansion pipe exhausting to atmosphere. Cylinder and pipe work should be lagged to minimise heat loss.

This diagram illustrates the basic principal of water heating systems and must not be regarded as a working drawing.

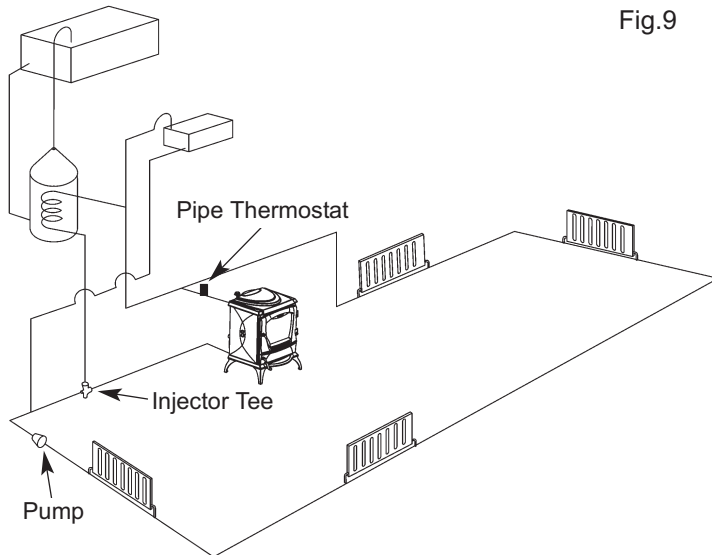

Fig.9

INJECTOR TEE

Where the gravity and central heating circuits join together to return to the stove we recommend the use of an injector tee connection, situated as close to the unit as possible. This type of tee encourages a stable flow of hot water through both circuits and helps to prevent priority being given to the stronger flow, which is most commonly the pumped central heating circuit. This way, there will be no shortage of hot water to the taps when the heating is on.

WATER CIRCUIT TEMPERATURE

The return water temperature should be maintained at not less than 40°C so as to avoid condensation on the boiler and return piping. Fitting a pipe thermostat to the flow pipe of the gravity circuit and wiring it into the pump control will ensure rapid circulation of the hot water.

In some circumstances it may be possible to overheat the appliance and the water inside will boil. This will be evident by the sound of a knocking noise coming from the appliance and pipes around the house. If this occurs close off all air controls and manually start the central heating pump if fitted. One radiator on the heating circuit should be uncontrolled to act as a heat leak in the event that the appliance overheats and has nowhere to discharge a build up of hot water should the heating circuit be satisfied. Be aware that steam and boiling water will be expended from any open vent from the heating

system probably in the roof space at the expansion tank.

In the unlikely event that the appliance is not operating in freezing conditions the water must be drained from the boiler to prevent frost damage.

PIPE THERMOSTAT

The fitting of a pipe thermostat to the flow pipe is essential in order to activate the water circulation pump when the water reaches the selected temperature.

When the water temperature falls below the selected temperature the pipe thermostat will cut off the water circulation pump in order to allow the boiler to recover.

Fig.10

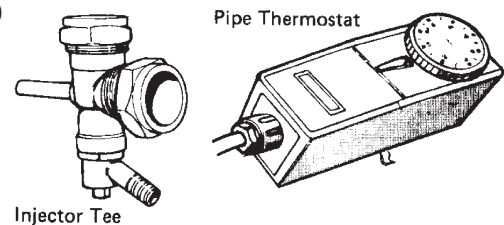

HANDOVER

On completion of the installation allow a suitable period of time for any fire cement and mortar to dry out, when a small fire may be lit and checked to ensure the smoke and fumes are taken from the stove up the chimney and emitted safely to the atmosphere. Do not run at full output for at least 24 hours.

Ensure that the operating instructions for the stove are left with the customer. Ensure to advise the customer on the correct use of the appliance with the fuels likely to be used on the stove and warn them to use only the recommended fuels for the stove.

Advise the user what to do should smoke or fumes be emitted from the stove. The customer should be warned to use a fireguard to BS 6539 in the presence of children, aged and/or infirm persons.

IMPORTANT NOTES

Now that your Solid Fuel Stove is installed and no doubt you are looking forward to many comforts it will provide, we would like to give you some tips on how to get the best results from your stove.

1. We would like if you could take some time to read the operating instructions/hints, which we are confident, will be of great benefit to you.
2. Do not burn fuel with a high moisture content, such as a damp peat or unseasoned timber. This will only result in a build up of tar in the stove and in the chimney.

| FUEL CALORIFIC VALUES - SOLID FUELS | | |
|--|----------------|----------------|
| Anthracite 25-50mm | C.V.: 8.2kW/Kg | 14,000 BTUs/lb |
| House Coal 25-75mm | C.V.: 7.2kW/Kg | 12,000 BTUs/lb |
| Timber - Firebox size | C.V.: 5.0kW/Kg | 8,600 BTUs/lb |
| Peat Briquettes | C.V.: 4.8kW/Kg | 8,300 BTUs/lb |

3. **Clean the flue-ways of the stove weekly and ensure that there are no blockages. Check flueways before lighting especially after a shut down period. Please refer to manual for instructions.**
4. Always ensure ashpan lid is removed from ashpan before lighting the stove.
5. Before loading fresh fuel into the firebox, riddle fully to remove all ashes this will allow better and cleaner burning. See Re-Fuelling section.
6. Never allow a build up of ashes in the ash pan, as this will cause the grate to burn out prematurely. Empty the ashpan when refuelling.
7. Allow adequate air ventilation to ensure plenty of air for combustion.
8. Do not use as an incinerator burning rubbish/household waste.
9. Do not leave ash-door open for long periods as this will over heat the unit causing unnecessary damage. Close the ash door between removing and replacing the ashpan.
10. Clean the chimney at least twice a year.
11. Burning soft fuels such as timber and peat will stain the glass. Regular cleaning will prevent permanent staining. Clean with soapy water when cool.
12. Keep all combustible materials a safe distance away from unit, please see section for clearances to combustibles.
14. Do not use an aerosol spray on or near the stove when it is alight.
15. For safety reasons never leave children or the elderly unaccompanied while stove is in use. Use a fire guard.
16. Avoid contact with the appliance when in use as stove reaches very high operating temperatures.
17. This appliance should be regularly maintained by a competent service engineer.

Use only replacement parts recommended by Stanley. Making unauthorised modifications, or using unauthorised parts will invalidate your guarantee and may cause damage or injury.

AN ODOUR WILL EMIT FROM STOVE ON FIRST FIRING, WHEN FIRE REACHES MAXIMUM TEMPERATURE OVER A NUMBER OF HOURS THE ODOUR WILL SUBSIDE. IT IS BEST ADVISED TO OPEN WINDOWS DURING THIS PERIOD.

THE ODOUR IS UNPLEASANT BUT NOT TOXIC. YOU MAY WISH TO VACATE THE ROOM WHILE THE PAINT CURES.

LIGHTING

Before lighting the stove check with the installer that the installation work and commissioning checks described in the installation instructions have been carried out correctly and that the chimney has been swept clean, is sound and free from any obstructions. As part of the stove's commissioning and handover the installer should have demonstrated how to operate correctly.

Fig.11

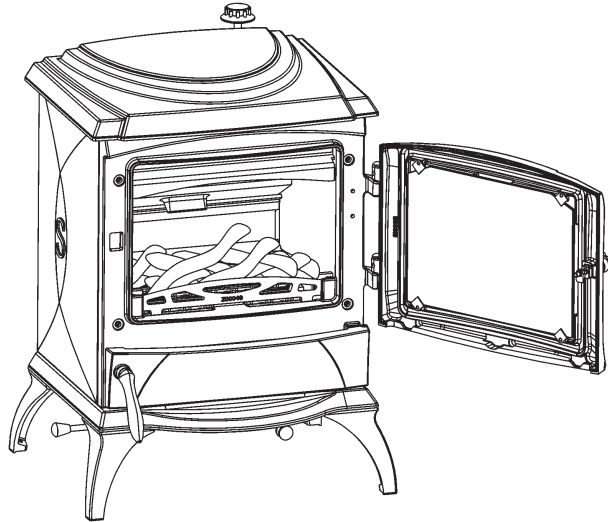

1. Open fire door and open the primary air inlet by turning the control knob on the right hand side of the stove to setting 4 on the thermostat.
2. Open the secondary air inlet by pulling it out fully.
3. Cover with crumpled pieces of paper.
4. Lay 10-12 pieces of kindling on top of the paper towards the back of the firebox.
5. Ignite and close the fire door.
6. **Under no circumstances should any flammable liquid i.e. petrol, paraffin etc., be used to light the fire.**
7. When the kindling is well alight open the fire door and add more kindling of a larger size to sustain the fire. Close the fire door.
8. When a hot fuel bed is established add the normal fuel.
9. When well lighted, adjust the thermostat to give the required heat output.
10. To shut the fire down, do not add fuel, make sure that the fire door is properly closed and that the primary and secondary air controls are all in the closed position. Cutting off the air supply will reduce the heat output.
11. Following a prolonged shutdown of the appliance perhaps after the summer break, ensure the flueway is free from obstruction prior to re-lighting.

Re-fuelling-Open the fire door and reload, close the fire door.

OPERATING INSTRUCTIONS

RECOMMENDED FUELS

All fuels should be stored under cover and kept as dry as possible prior to use.

This appliance has been tested using seasoned wood logs and manufactured briquetted smokeless fuel (Ancit) for closed appliances, sized between 20g and 140g. Other fuels are commercially available and may give similar results. Wood logs up to 380mm long are suitable. All fuels should be stored under cover and kept as dry as possible prior to use.

Do not use fuels with a Petro-coke ingredient as this may cause the grate to overheat, causing damage. Reduced outputs will result when fuels of lower calorific values are used. Never use gasoline or gasoline type lantern fuel, kerosene, charcoal lighter fluid or similar liquids to start or freshen up a fire in this heater. Keep all such liquid well away from the heater at all times. Operate the stove only with the fuelling door closed except for re-fuelling.

This stove has obtained HETAS Ltd approval for burning natural and manufactured smokeless fuels only as detailed in recommended fuels below. HETAS Approval does not cover the use of other fuels either alone or mixed with the recommended fuels listed, nor does it cover instructions for the use of other fuels.

WARNING:

Properly installed, operated and maintained this stove will not emit fumes into the dwelling. Occasional fumes from de-ashing and re-fuelling may occur. However, persistent fume emission is potentially dangerous and must not be tolerated. If fume emission does persist, then the following immediate action should be taken -

- Open doors and windows to ventilate room and then leave the premises.
- Let the fire out.
- Check for flue or chimney blockage and clean if required.
- Do not attempt to relight the fire until the cause of the fume emission has been identified and corrected. If necessary seek expert advice.

The most common cause of fume emission is flue-way or chimney blockage. For your own safety these must be kept clean at all times.

THERMOSTAT OPERATION

Fig.12

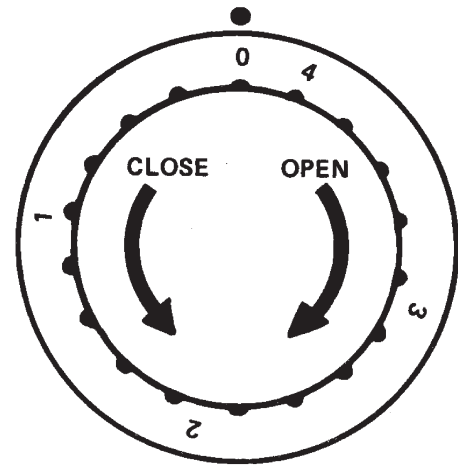

| | | |
|-------------------|------------------|--------------------------|
| Setting 0: | Closed | Overnight Burning |
| Setting 1: | 1/4 Open | |
| Setting 2: | 1/2 Open | Slowburning |
| Setting 3: | 3/4 Open | Medium burning |
| Setting 4: | Full Open | Maximum Heat |

Rotate the knob to give the required burning rate.

SECONDARY AIR CONTROL

| | |
|--------------|--|
| OPEN | When burning coal, timber or peat. |
| CLOSE | When burning anthracite and smokeless fuels. |

Fig.13

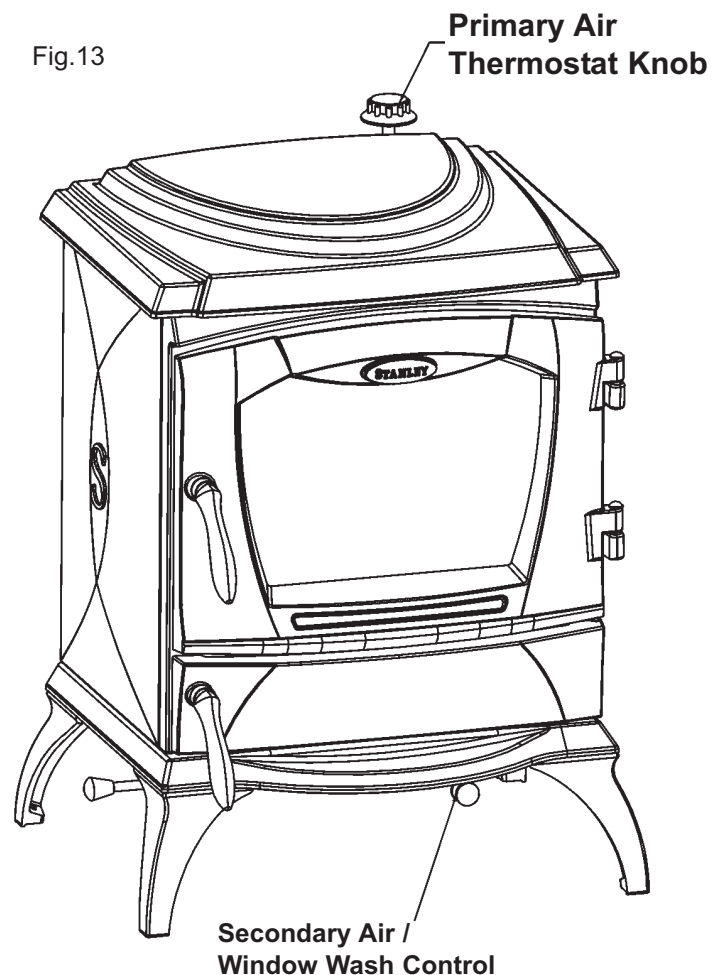

The secondary air control knob may be hot when the appliance is in use. The ashpan handle is a combined operating tool and can be used to operate this knob or use the glove provided. To open the secondary air, locate the knob under the base on the right of the stove. Push to OPEN and pull to CLOSE.

DE-ASHING

When ash build-up becomes excessive in the fire chamber shake the firebars by pushing and pulling the riddling rod repeatedly. The riddling rod is located under the base at the left side of the stove.

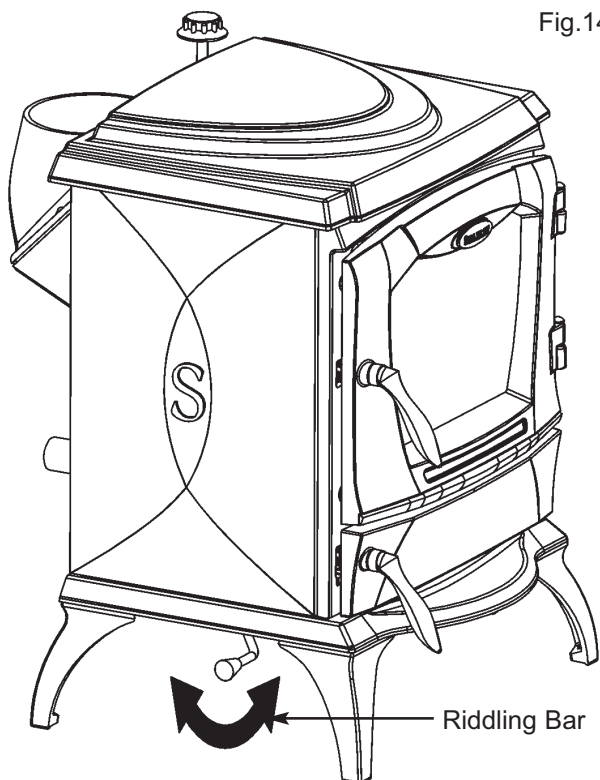

DISPOSAL OF ASHES

Your stove is provided with a steel ashpan. This ashpan should be emptied every day.

If ashes are allowed to build to grate level you could damage the firebars by overheating. We recommend that you remove ashes after you have riddled the fire following overnight burn.

Ashes should be placed in a metal or other non-combustible container with a tight fitting lid. The closed container of ashes should be placed on a non-combustible material, pending final disposal. If ashes are buried in soil, or otherwise dumped they should be retained in the closed container until they are thoroughly cooled. See Fig.15.

Fig.15

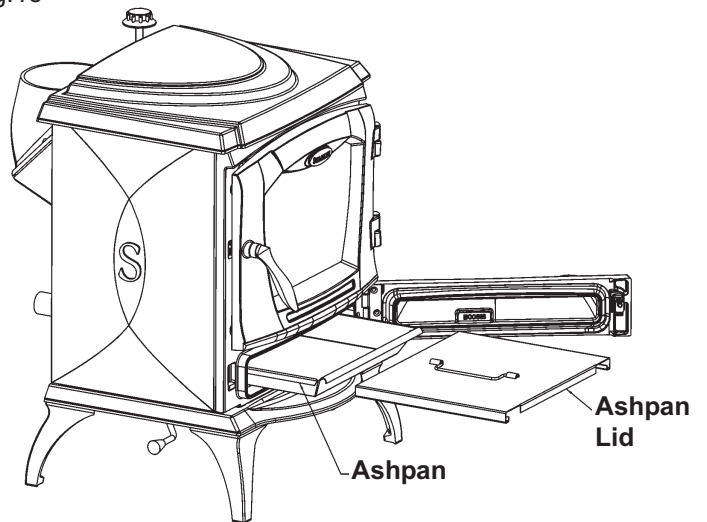

TO CLEAN CHIMNEY BACK OUTLET

Remove baffle underneath the boiler cross flow chamber by lifting it upwards and pulling it outwards and insert cleaning brush. Replace baffle before lighting fire.

When fitted correctly the baffle should fall forward to close onto the bottom of the boiler. The appliance will not function correctly with this baffle misaligned or missing.

Fig.16

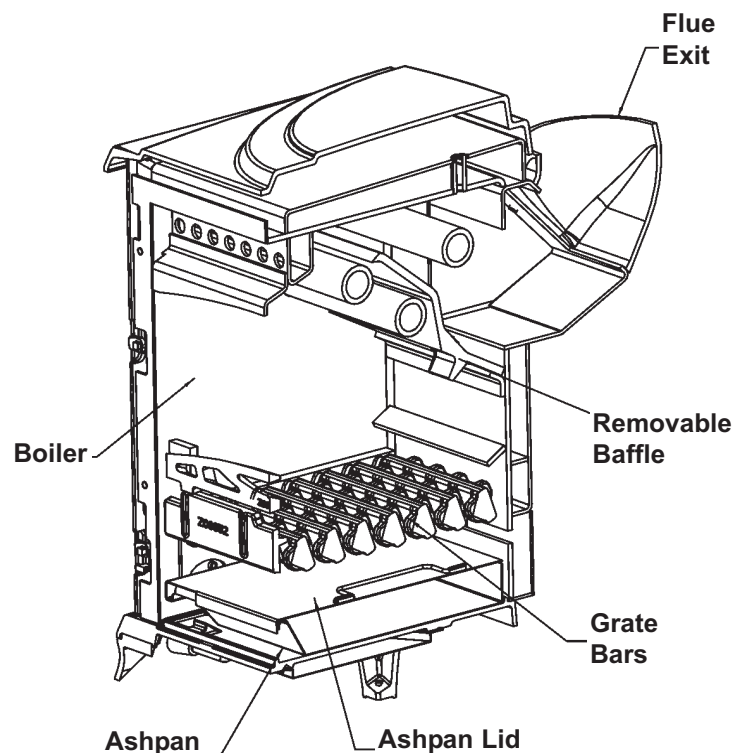

CHANGING GRATE ORIENTATION

For best combustion of coal it is best to burn it on an open grate as the ash needs to be frequently removed to avoid a build up of ash on the grate.

For best combustion of wood it is best to use a flat grate so that it can build up a bed of ash as it burns.

The grate on the Lismore Stove can be changed from a coal setting to wood burning setting.

The product is supplied in the coal burning setting, this should not be changed if a mixture of fuels are being used i.e. (coal, wood, peat, anthracite). If burning wood only, change the grate setting by opening the ash door and remove the ash pan. This should reveal a hex head bolt on the left hand side which should be removed, with the bolt removed the riddling bar can now be moved to the wood burning position.

The hex head bolt should now be re-inserted in the alternative position which will lock the grate in the wood burning position. See Fig.19

See Fig, 17 & 18 showing the position of the grate for wood burning and coal burning, note the position of the riddling rod also.

WARNING - DO NOT CHANGE GRATE POSITION WHEN STOVE IS HOT.

Wood Setting

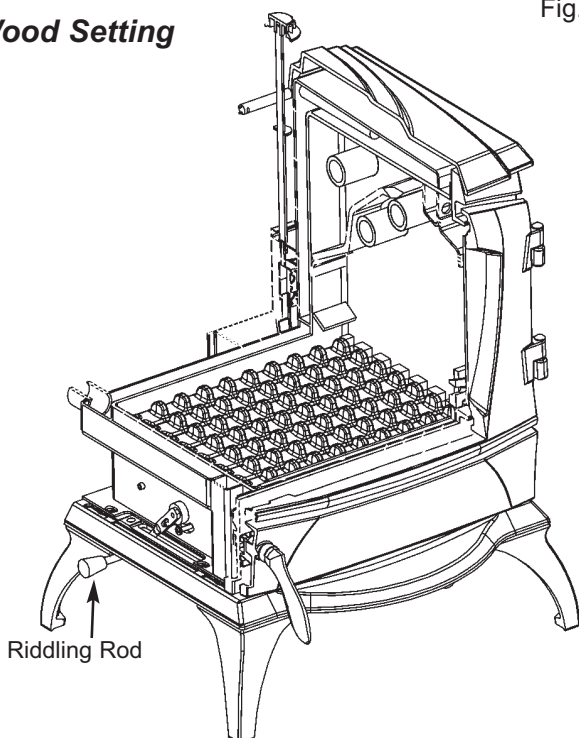

Fig.17

Fig.18

Coal Setting

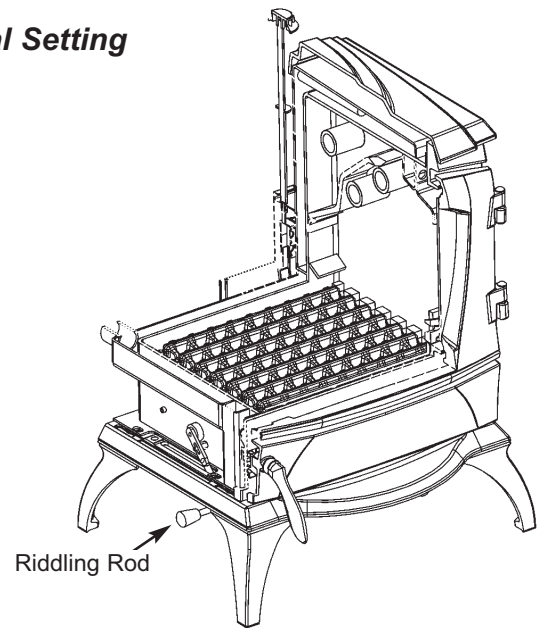
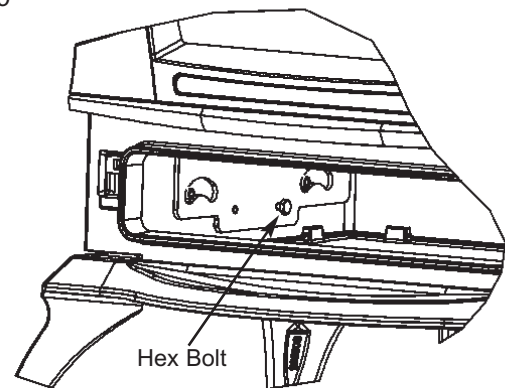

Fig.19



FIRE SAFETY

To provide reasonable fire safety, the following should be given serious consideration.

1. Do not over fire the stove.
2. Over-firing will also damage painted or enamel finish.
3. Install a smoke detector in the room.
4. A conveniently located class A fire extinguisher to contend with small fires resulting from burning embers.
5. A practical evacuation plan.
6. A plan to deal with a chimney fire as follows:-
 - (a) Notify the fire department.
 - (b) Prepare occupants for immediate evacuation.
 - (c) Close all openings into the stove.
 - (d) While awaiting the fire department watch for ignition to adjacent combustibles from overheated flue pipe or from embers or sparks from the chimney.

VITREOUS ENAMEL CLEANING

General cleaning must be carried out when the stove is cool.

If this stove is finished in a high gloss vitreous enamel, to keep the enamel in the best condition observe the following tips:

1. Wipe over daily with a soapy damp cloth, followed by a polish with a clean dry duster.
2. For stubborn deposits a soap impregnated pad can be carefully used on the vitreous enamel.
3. Use only products recommended by the Vitreous Enamel Association, these products carry the Vitramel label.

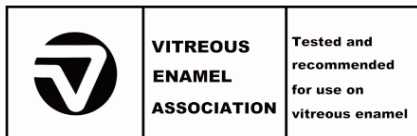

4. **DO NOT USE ABRASIVE PADS OR OVEN CLEANSERS CONTAINING CITRIC ACID ON ENAMELLED SURFACES. ENSURE THAT THE CLEANSER MANUFACTURERS INSTRUCTIONS ARE ADHERED TO.**

FROZEN SYSTEM

If there is any possibility that the water system may be frozen do not attempt to light the stove until you are certain there is no ice in the system possibly causing a blockage.

GLASS CLEANING

The glass will self clean when there is sufficient heat generated by the burning fuel. If a build-up of creosote occurs on the glass it may be due to draft conditions, poor quality fuel or very low burning for a long time. It is best to clean the glass when it is thoroughly cooled.

Fig. 20

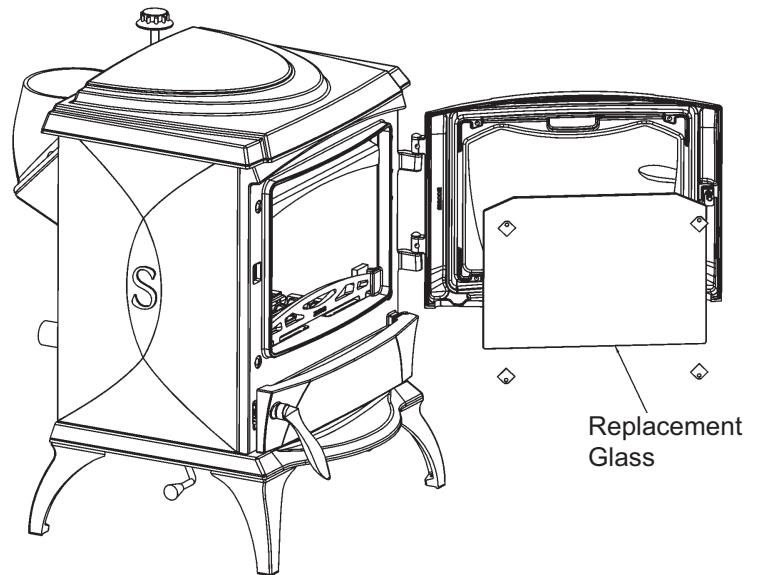

GLASS REPLACEMENT

- (a) Open the fire door fully.
- (b) Remove the four corner screws and clips and carefully remove the broken glass.
- (c) Clean the glass recess in the door.
- (d) Replace the sealing rope in the door if necessary
- (e) Tighten screws.
- (f) Replace glass only with ceramic glass 5mm thick. (See Fig.20).

SUMMER SHUTDOWN

For summer shutdown of the stove, ensure all ashes have been cleaned from the ash compartment and that the air control is open, to avoid condensation in the stove firebox and possible corrosion during this shutdown period.

EXPLODED VIEW

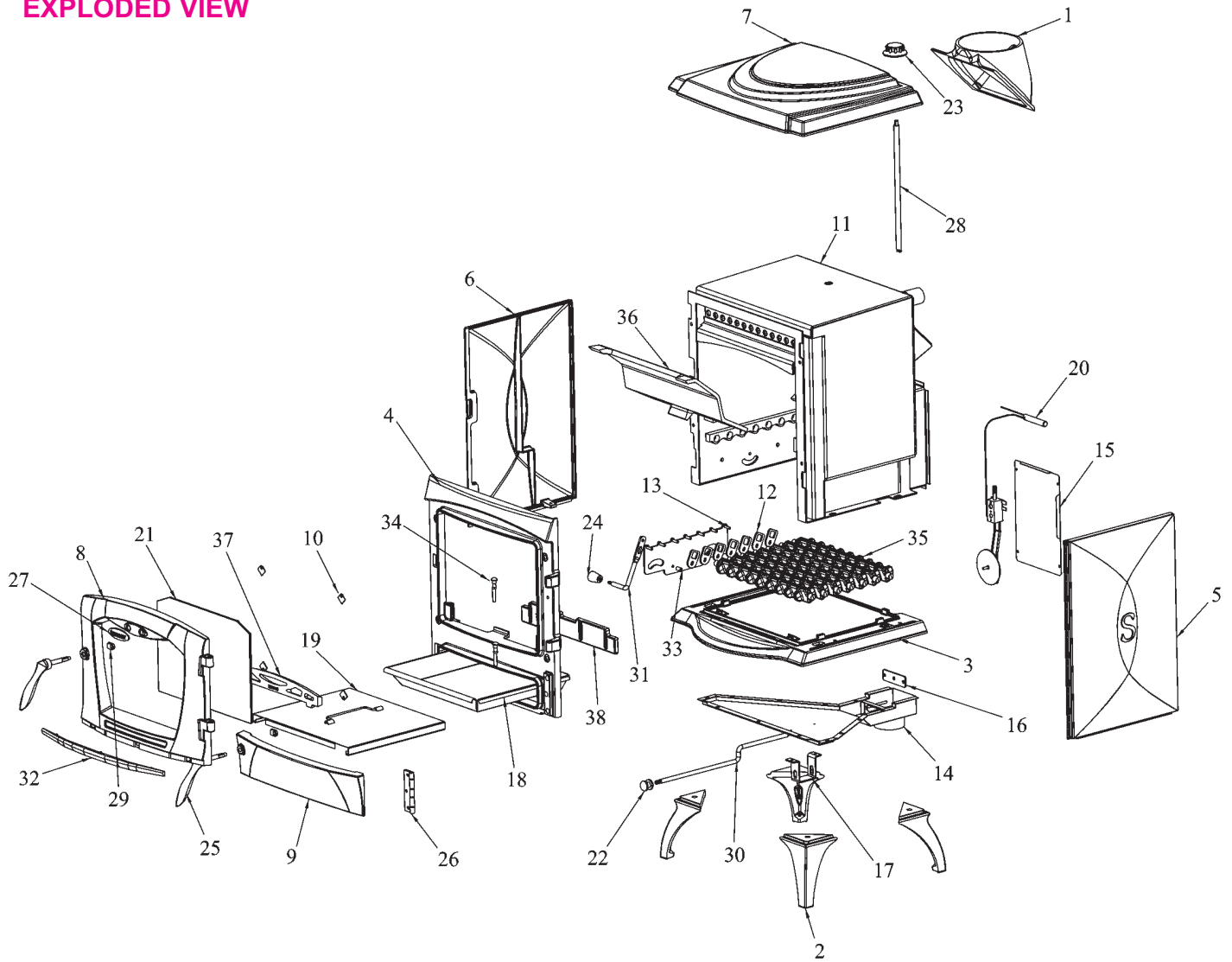

- | | |
|--|--|
| 1. FLUE SPIGOT - B00116AZZ | 21. GLASS - T00101AXX |
| 2. STOVE LEG - B00595AZZ | 22. PULL ROD KNOB - U00001AXX |
| 3. BASE - B00610AZZ | 23. AIR CONTROL KNOB - U00006AXX |
| 4. FRONT - B00611AZZ | 24. KNOB SECONDARY AIR DAMPER - U00018AXX |
| 5. RIGHT HAND SIDE - B00612AZZ | 25. Door Handle - U00191AXX |
| 6. LEFT HAND SIDE - B00613AZZ | 26. HINGE - U00193AXX |
| 7. HOB - B00614AZZ | 27. BADGE - V00912AXX |
| 8. FIREDOOR - B00615AZZ | 28. THERMOSTAT CONTROL ROD - V00938AXX |
| 9. ASH DOOR - B00616AZZ | 29. DOOR CATCH - V00985AXX |
| 10. DOOR GLASS CLIP - F00003AXX | 30. DAMPER ROD - V00988AXX |
| 11. LISMORE BOILER - F01067AXX | 31. RIDDLING ROD - V00989AXX |
| 12. RIDDLING LINK - F01068AXX | 32. FRONT STRIP - V00990AXX |
| 13. LINK BRACE - F01069AXX | 33. SPACER - V00991AXX |
| 14. AIR CHANNEL COVER - F01071AXX | 34. HINGE PIN (CAM ACTION) - V00997AXX |
| 15. OSA BOX COVER - F01072AXX | 35. RIDDLING BAR - Z00047AXX |
| 16. DAMPER - F01073AXX | 36. FLUE CLEANING DOOR - Z00048AXX |
| 17. BRACKET - F01074AXX | 37. FIRE FENCE - Z00049AXX |
| 18. ASHPAN BODY - F01075AXX | 38. FRONT PROTECTION PLATE - Z00052AXX |
| 19. ASHPAN COVER - F01082AXX | |
| 20. QWX THERMOSTAT - G00479AXX | |

INSTALLATION CHECK LIST

Flue System

Tick

1. Minimum Flue Height of 4.6 metres (15 feet).
2. Appliance should be connected to a minimum of 1.8 metres (6 feet) of 150mm (6") flue pipe with a horizontal run not exceeding 300mm (12").
3. Appliance should be connected to a chimney of less than 200mm (8") in diameter (otherwise the chimney must be lined with a 6" flue liner).
4. The chimney venting position must be above the main ridge of the roof or adjacent outside obstructions.
5. The chimney serving this appliance should not serve any other appliance.
6. Access should be provided to the chimney serving the appliance to allow for cleaning.

Location

7. Clearance to combustible materials must be adhered to as described in the Clearance to Combustible section.
8. The stove must be installed on a floor protector that covers the area under the stove and extends 18" to the front & 8" to the sides and back.

Plumbing

9. Appliance must be connected to a gravity circuit using 1" ID flow & return piping.
10. The length of pipes from the cylinder to the cooker should not exceed 7.8 metres (25¹/₂ feet).
11. A circulation pump should be fitted to the return pipe of the radiator circuit and controlled by a pipe stat fitted to the flow pipe of the gravity circuit to the cylinder.

Ventilation & Combustion Air Requirements

12. The room in which the appliance is located should have an air vent of adequate size to support correct combustion (see Ventilation & Combustion Air Requirement Section for specific details).



**Manufactured by
Waterford Stanley Ltd.,**
Unit 210, IDA Industrial Estate, Cork Road,
Waterford, Ireland.
Tel: (051) 302300 Fax (051) 302315

