



**BUILT-IN
APPLIANCES**
2011 Collection

BEKO



Welcome to the world of Beko Built-In appliances where functionality and simplicity blend harmoniously with elegance and style.

The kitchen is increasingly the focal point of the home where we spend more and more time. It is where families get together and friends meet and chat. Combining the latest technology with modern aesthetics, the Beko Built-in range allows you to create affordable and contemporary kitchens designed to withstand the demands of a busy family life.

All Beko Built-In appliances are 'A' energy rated or better and offer a wide range of practical features suited to your individual needs.

The latest collection features two premium ovens that have the benefit of the 'Programme Clean' technology as well as offering 30% saving on energy. With a new front control panel design, the 60cm gas hob adds a great finishing touch to the cooking range. Both fridge freezers have also been upgraded to 'A+' for greater performance with minimal consumption.

Beko is proud to be a member of the KBSA reflecting the quality and design excellence of the 2011 product range.



Ovens

All Built-in ovens are 'A' energy rated - consuming 20% less energy than the standard 'A' class (excluding OIM25502).



OIM22500

Premium Multi Function 'Programme Clean' oven

Main Features

- Massive oven capacity 65 litres
- 'A' energy rated
- 2 cleaning programmes
 - Full 'Programme Clean' 120 minute cycle
 - Eco 'Programme Clean' 90 minute cycle
- Large display programmable electronic timer
- Telescopic shelf system
- 'Easy clean' four glass layer 'Cool Door' system
- Maximum oven visibility - large viewing window and interior light
- Diamond Quality easy clean enamel oven interior
- Push-in Push-out control knobs
- Fingerprint-free stainless steel

Technical Information

- Fully variable grill function
- 14 function settings including 2 cleaning programmes
- Wire shelf with stop position
- Full width enamel cooking tray with internal grill rack

Stainless Steel - OIM22500XP



OIF22300 XL/XR

Fan Oven with Left or Right Hand Side Opening Door & LED Programmer

Main Features

- Massive oven capacity 65 litres
- 'A' energy rated
- Easy access side opening door
- Telescopic runner system
- Programmable oven with large display LED timer
- Recessed grill element
- Easy grip silver coloured matching control knobs
- 'Easy Clean' double glazed oven door with full glass inner door
- Maximum oven visibility - large viewing window and interior light
- Diamond quality easy clean enamel oven interior

Technical Information

- Fully variable grill function
- 4 function settings
 - Fan heating
 - Variable grill
 - Fan and grill
 - Defrost
- One wire shelf with stop position system
- Full width enamel cooking tray with internal grill rack

Stainless Steel - OIF22300XL (Left hand hinge)

Stainless Steel - OIF22300XR (Right hand hinge)



OIM25502

Premium Multi Function Oven

Main Features

- Massive oven capacity 65 litres
- Gloss control panel fascia
- Large display programmable electronic timer
- Telescopic shelf system
- Catalytic liners on back wall
- Push-in Push-out control knobs
- Low energy consumption fan cooking programme
- 'Easy clean' double glazed oven door with full glass inner door
- Maximum oven visibility - large viewing window and interior light
- Diamond Quality easy clean enamel oven interior

Technical Information

- Fully variable grill function
- 12 function settings
- Wire shelf with stop position
- Full width enamel cooking tray with internal grill rack

Stainless Steel - OIM25502X



OIM22300

Multi Function Oven with LED Programmer

Main Features

- Massive oven capacity 65 litres
- 'A' energy rated
- Programmable oven with large display LED timer
- Recessed grill element
- Easy grip silver coloured matching control knobs
- 'Easy clean' double glazed oven door with full glass inner door
- Maximum oven visibility - large viewing window and interior light
- Diamond quality easy clean enamel oven interior

Technical Information

- Fully variable grill function
- 8 function settings
 - Fan/Defrost
 - Static
 - Static and fan
 - Fan heating
 - Bottom heater
 - Low grill fan
 - Grill
 - 3D Cooking
- Two wire shelves
- Full width enamel cooking tray with internal grill rack

Stainless Steel - OIM22300X

'A' energy rated - consuming 30% less energy than the standard 'A' class



OIF22300 / OIF21300

60cm Fan Oven with LED Programmer

Main Features

- Massive oven capacity 65 litres
- 'A' energy rated
- Programmable oven with large display LED timer
- Recessed grill element
- Easy grip silver coloured matching control knobs
- 'Easy clean' double glazed oven door with full glass inner door
- Maximum oven visibility – large viewing window and interior light
- Diamond Quality easy clean enamel oven interior

Technical Information

- Fully variable grill function
- 4 function settings
 - Fan heating
 - Variable grill
 - Fan and grill
 - Defrost
- Two wire shelves
- Full width enamel cooking tray with internal grill rack

White - OIF21300W

Stainless Steel - OIF22300X

Black - OIF21300B



OIF21100 / OIF22100

60cm Fan Oven with Minute Minder

Main Features

- Massive oven capacity 65 litres
- 'A' energy rated
- 100 min auto-cut off mechanical minute minder
- Recessed grill element
- 'Easy clean' double glazed oven door with full glass inner door
- Maximum oven visibility – large viewing window and interior light
- Diamond quality easy clean enamel oven interior

Technical Information

- Fully variable grill function
- 4 function settings
 - Fan heating
 - Variable grill
 - Fan and grill
 - Defrost
- Full metal control panel
- Easy grip control knobs
- Two wire shelves
- Full width enamel cooking tray with internal grill rack

White - OIF21100W

Stainless Steel - OIF22100X



ODF22300 / ODF21300

90cm Built In Double Oven

Main Features

- Fan main oven, top conventional oven with integral grill
- 'AA' energy rated
- Large capacity main oven compartment (65 litres)
- Programmable oven with large display LED timer
- Recessed grill element
- 'Easy clean' double glazed glass door with large viewing window
- Diamond quality easy clean enamel oven interior

Technical Information

- Main fan oven – 2 functions
 - Fan heating
 - Defrost
- Top oven - 4 functions
 - Top and bottom heat
 - Bottom heater
 - Grill
 - Low grill
- Easy grip control knobs
- Three wire shelves with stop position system
- Standard baking tray with internal grill rack and handle

White - ODF21300W

Stainless Steel - ODF22300X

Black - ODF21300B



OTF12300

72cm Built Under/In Column Double Oven

Main Features

- Large fan main oven and top conventional oven with fully variable grill
- 'AB' energy rated
- Large display programmable LED timer (main oven)
- Recessed grill element
- Easy grip silver colour control knobs
- 'Easy clean' double glazed glass door with large viewing window
- Diamond quality easy clean enamel oven interior

Technical Information

- Full metal control panel
- Main fan oven – 2 functions
 - Fan heating
 - Defrost
- Top oven - 4 functions
 - Top and bottom heat
 - Bottom heater
 - Grill
 - Low grill
- Three wire shelves with stop position system
- Full width enamel cooking tray with internal grill rack

Stainless Steel - OTF12300X



HII64401T

60cm Touch Control Induction Hob

- 4 induction ceramic zones
- 9 cooking levels per zone
- Booster function for quick heating
- Child lock
- Timer and buzzer
- On and off indicator light
- Wipe clean ceramic glass surface



HIG75221S

70cm Gas Hob

- 5 Burners, including triple ring wok burner
- Flame Safety Device for all burners
- Adjustable flame settings
- Cast iron pan supports
- Automatic mains ignition on all burners
- Suitable for LPG conversion

Stainless Steel - HIG75221SX



HIC64402T

60cm Touch Control Ceramic Hob

- Frameless ceramic hob
- Easy to clean hob surface
- Dual zone provides cooking flexibility
- 4 Rapidlite heating zones
- 1-9 adjustable power levels
- Timer
- Child lock – for safety
- Auto shut off – If left on for a long period of time
- 4 residual heat indicators



HIG64221S

60cm Front Control Gas Hob

- 4 burner gas hob
- High-output triple ring wok burner
- FSD on all burners
- Cast iron pan supports
- Automatic main ignition on all burners
- Suitable for LPG conversion

Stainless Steel - HIG64221SX

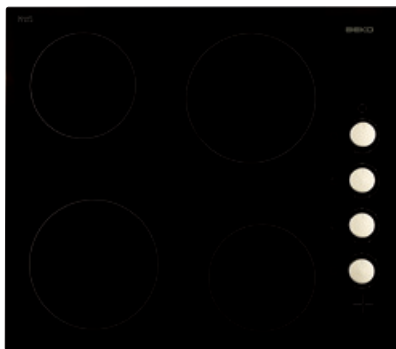

HIC64102

60cm Frameless Ceramic Hob

- Easy to clean hob surface
- Easy grip side control knobs
- 4 Rapidlite heating zones
- 1-6 adjustable power levels
- 4 residual heat indicators



HIZG64120

60 cm Gas Hob with Auto Ignition

- 4 burner gas hob with 3 different sizes
- FSD on all burners
- Enamel pan supports
- Automatic mains ignition
- Easy grip control knobs
- Easy to clean one piece hob plate
- Suitable for LPG conversion

White - HIZG64120SW

Stainless Steel - HIZG64120SX

Black - HIZG64120SB

Hobs



HIZE64101

60 cm Sealed Plate Electric Hob

- Easy to clean one piece hob plate
- 4 sealed plates with 4 rapid zones
- On/off power light
- Residual heat indicator

White - HIZE64101W

Stainless Steel - HIZE64101X

Microwave



MWB2511

Built-In Microwave and Grill

Main Features

- Digital programmer
- 3 auto step cooking functions
- 5 microwave power levels
- 2 grilling levels
- Defrost function
- Quick start
- Electronic child lock
- Fingerprint free
- Interior lighting
- Built-in installation with frame
- MW power level: 900W
- Grill power: 1200 W

Stainless steel - MWB2511X

Hoods



HB60P

Cooker Hood

Main Features

- Simple push button controls
- 2 high quality aluminium grease filters
- 3 speed extraction system
- 400m³/h maximum extraction
- 2 x 40W illumination bulb
- Extendable ducting spigot 120-150mm
- Recirculation filter included

Stainless Steel - HB60PX



HBV60

Cooker Hood

Main Features

- Simple slider controls
- 2 acrylic grease filters
- 3 speed extraction system
- 210m³/h maximum extraction
- 120mm ducting diameter
- 1 x 40W illumination bulb

Stainless Steel - HBV60X

Laundry



WMI71641

Integrated Washing Machine

Main Features

- 'A+AA' energy rated
- 7kg 1600rpm
- Interactive LCD with time remaining display
- 16 programmes including:
 - 14 minute small load wash
 - 39 minute full load wash
 - Baby and toddler clothing
- Delay timer up to 24hrs
- Variable spin and temperature
- 4 height adjustable feet

MARKET LEADING
CAPACITY & MAXIMUM
SPIN SPEED



BWD6421

Fully Integrated Washer Dryer

Main Features

- 'BAC' energy rated
- 1200rpm
- 6kg washing and 4kg drying capacity
- LCD display showing time remaining
- Time delay up to 24 hours
- Spin speed reduction button
- 15 wash programmes including:
 - Quick wash
 - Wool
 - Intensive
 - Delicates
 - Cold wash
- Safety lock during wash cycles
- 4 adjustable feet

Dishwashers

Easy installation - front adjustment for rear feet



DW450

Slimline Dishwasher

Main Features

- 'AAA' energy rated
- Noise level 49dBA
- 10 place settings
- Electronic programme chooser
- 5 wash programmes
 - Pre-wash
 - Economy
 - Intensive 70°C
 - Rapid
 - Quick and clean
- 4 wash temperatures

Technical Information

- Height adjustable upper basket
- Upper basket with folding racks
- Folding plate supports in lower basket
- Salt and rinse aid indicator lights
- Hot air drying system
- Removable cutlery basket



DW600

Full Size Dishwasher

Main Features

- 'AAA' energy rated
- Noise level 49dBA
- 12 place settings
- Electronic programme chooser
- 5 wash programmes
 - Pre-wash
 - Economy
 - Intensive 70°C
 - Rapid
 - Quick and clean
- 4 wash temperatures

Technical Information

- Easy to use height adjustable upper basket with folding racks
- Folding plate supports in lower basket
- Salt and rinse aid indicator lights
- Hot air drying system
- Sideways sliding cutlery basket

Fridge Freezers



BL20

'A' Rated Fully Integrated Larder Fridge

Main Features

- 'A' energy rated
- Reversible door
- Heavy duty self closing metal hinges to ensure door is not left ajar
- Sliding telescopic salad crisper cover
- Auto defrost
- Adjustable feet for levelling

Technical Information

- 4.6cu. ft. (130 litres) gross capacity
- 2 adjustable glass shelves
- 1 full width bottle rack
- 1 full width commodity rack



BZ30

'A' Rated Fully Integrated Freezer

Main Features

- 'A' energy rated
- Reversible door
- Heavy duty self closing metal hinges to ensure door is not left ajar
- Indicator lights:
 - Green: Mains on
 - Red: High temperature warning
 - Amber: Fast freeze activated
- Adjustable feet for levelling

Technical Information

- Manual defrost
- 3.4cu. ft. (96 litres) gross capacity
- Fast freeze switch
- 4 separate compartments:
 - Drop down flap
 - 2 drawers both with transparent front
 - Concealed compartment below bottom drawer

BC50F

'A+' Rated Combi Frost Free Fridge Freezer

Main Features

- 'A+' energy rated
- 8.1cu. ft. (230 litres) gross capacity
- Reversible doors
- Sliding hinges

Technical Information

Fridge

- 5.5 cu. ft. (155 litres) net capacity
- 3 adjustable glass shelves
- Chrome wire wine rack

Freezer

- 2.2 cu. ft. (62 litres) net capacity
- Four separate compartments
 - 3 full depth compartments, one with drop down flap
 - Half depth plastic drawer



BC501

'A' Rated Combi Fridge Freezer

Main Features

- 'A' energy rated
- 8.5cu. ft. (242 litres) gross capacity
- Reversible door
- Sliding hinges

Technical Information

Fridge

- 5.5 cu. ft. (156 litres) net capacity
- Adjustable glass shelves
- Chrome wire wine rack

Freezer

- Manual defrost
- 2.4cu. ft. (69 litres) net capacity
- Four separate compartments
 - 3 full depth compartments, one with drop down flap
 - Half depth plastic drawer

BC73F

'A+' Rated Combi Frost Free Fridge Freezer

Main Features

- 'A+' energy rated
- 9.7cu. ft. (275 litres) gross capacity
- Reversible doors
- Sliding hinges

Technical Information

Fridge

- 6.7 cu. ft. (189 litres) net capacity
- 3 adjustable glass shelves
- Chrome wire wine rack

Freezer

- 1.7 cu. ft. (48 litres) net capacity
- 3 separate compartments
 - 2 full depth compartments, one with drop down flap
 - Half depth plastic drawer



BC731

'A' Rated Combi Fridge Freezer

Main Features

- 'A' energy rated
- 10cu. ft. (283 litres) gross capacity
- Reversible door
- Sliding hinges

Technical Information

Fridge

- 6.7 cu. ft. (189 litres) net capacity
- Adjustable glass shelves
- Chrome wire wine rack

Freezer

- Manual defrost
- 1.9cu. ft. (55 litres) net capacity
- 3 separate compartments
 - 2 full depth drawers
 - 1 half depth drawer

OVENS (All ovens have plastic lined carry handles for ease of installation)

OIF22300 XL/XR, OIF22300/OIF21300,
OIF21100/OIF22100, OIM22300,
OIM25502, OIM22500
Aperture cut-out: H590 * W560 * D550

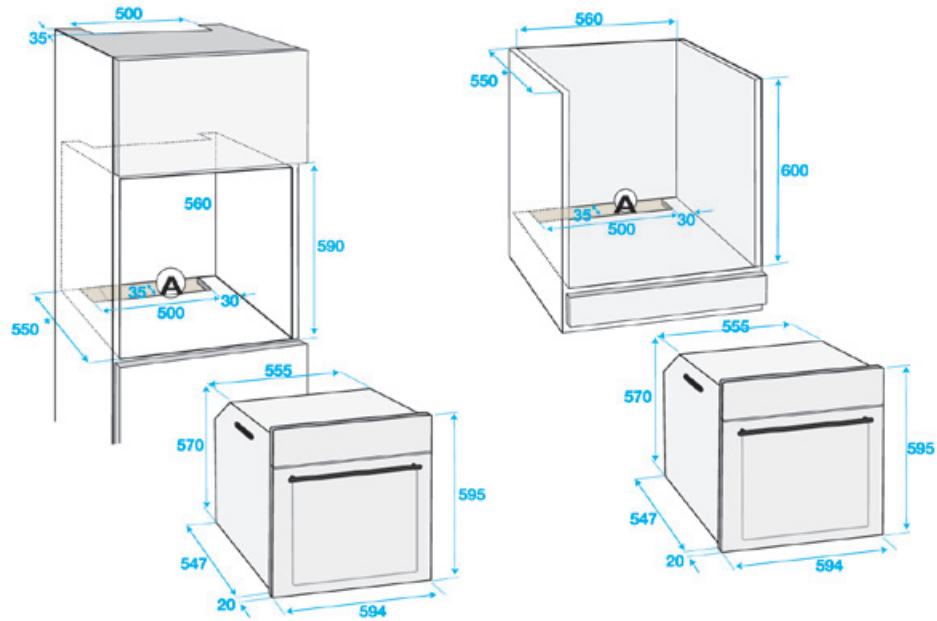

ODF22300/ODF21300
Aperture cut-out: H880 * W560 * D550

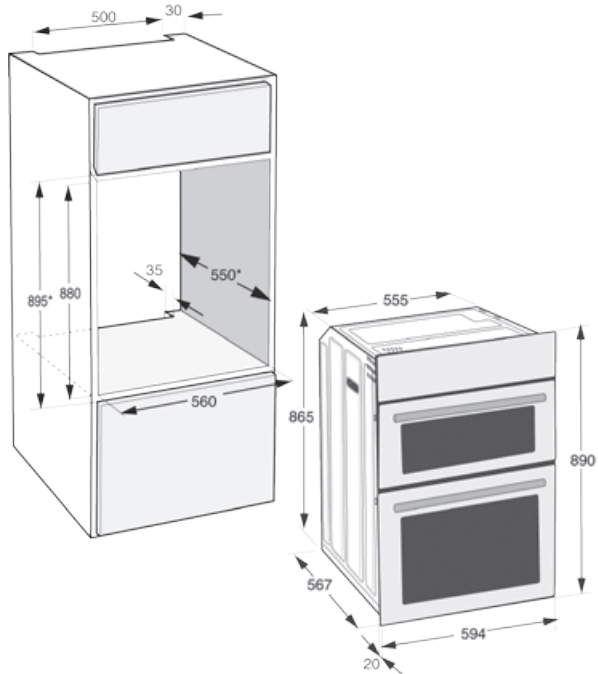

OTF12300
Aperture cut-out: H720 * W560-570 * D550

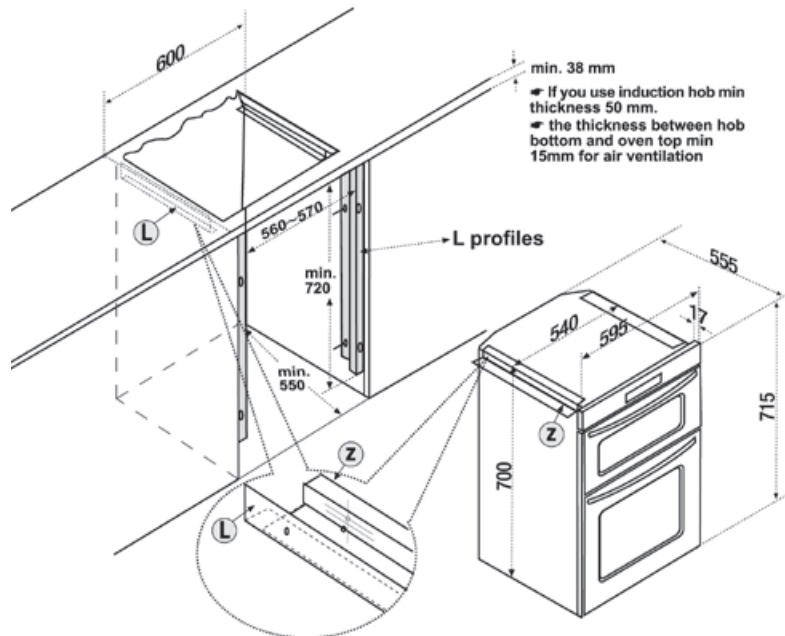

HOBS

HIC64102, HIZ64120/HIZE64101, HIC64402T
HII64401T, HIG64221S, HIG75221SX*
Aperture cut-out: W560 * D490

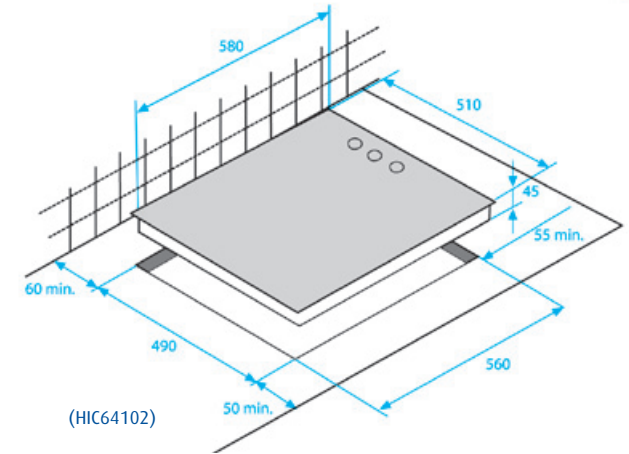

(HIC64102)

* 70cm gas hob has the same aperture cut out as 60cm hobs



FRIDGES

BC73F/BC50F (BC731/BC501)
Aperture cut-out: H1776-1789 * W560 * D550

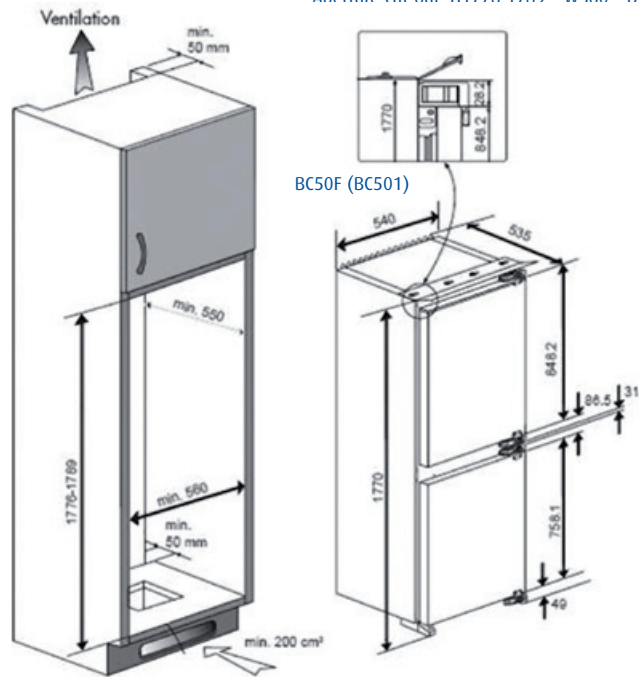

BC50F (BC501)

BL20/BZ30
Aperture cut-out: H820-870 * W600 * D550

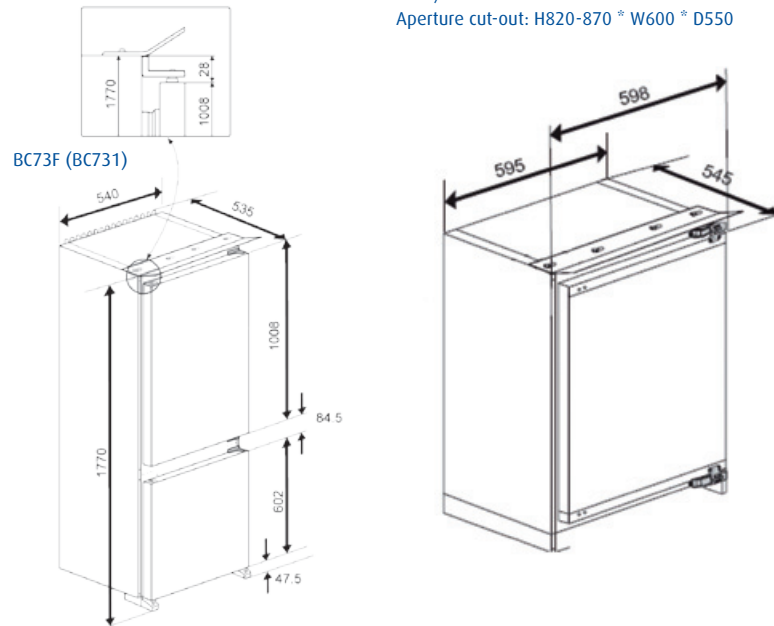

BC73F (BC731)

DISHWASHERS

DW450
Aperture cut-out: H820-920 * W450 * D570

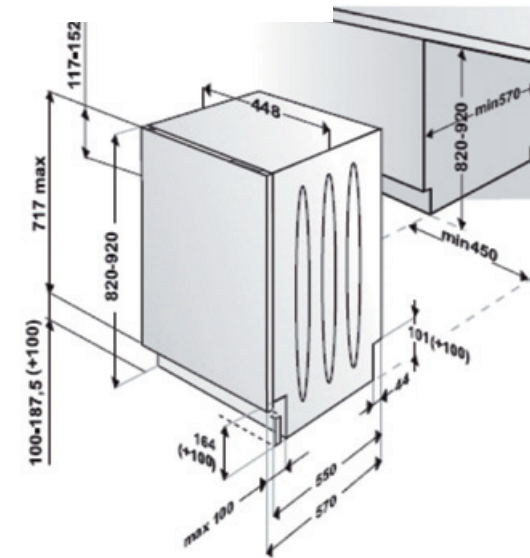

DW600
Aperture cut-out: H820-920 * W600 * D570

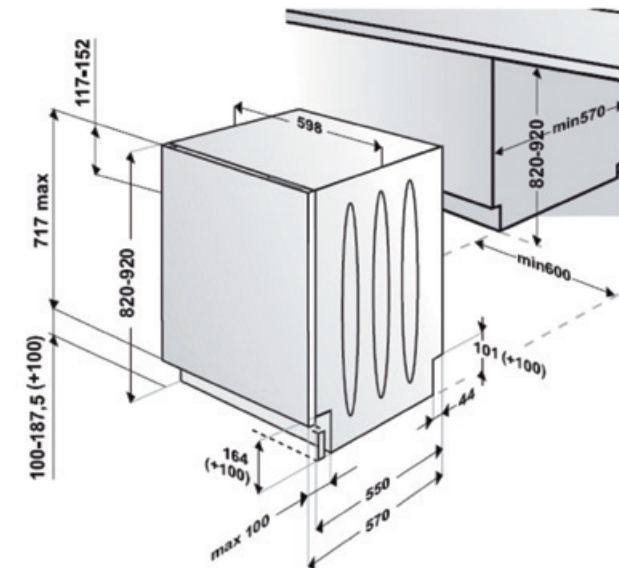

WASHING MACHINES

WMI71641

Aperture cut-out: H820 * W600 * D580

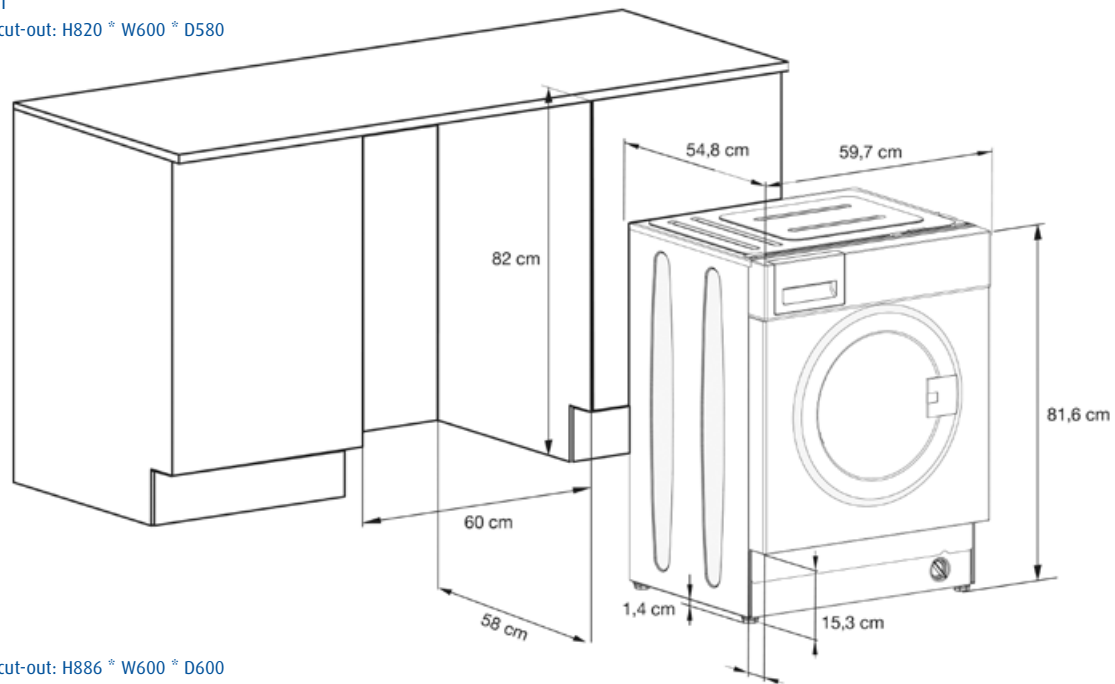

BWD6421

Aperture cut-out: H886 * W600 * D600

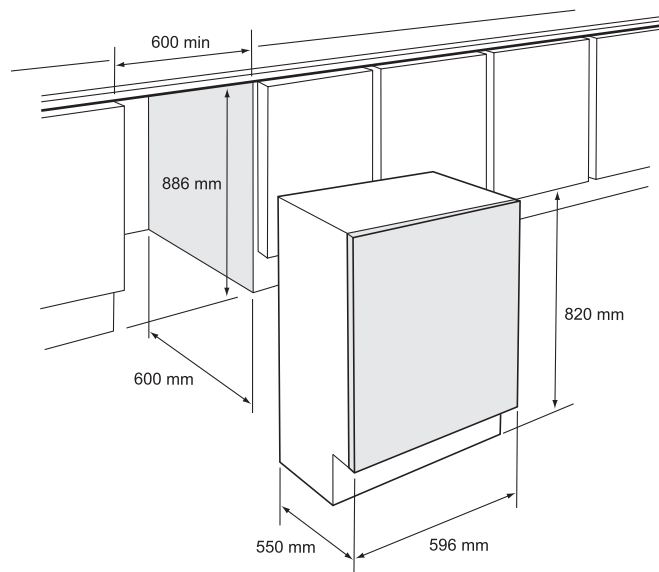

HOODS

HB60PX

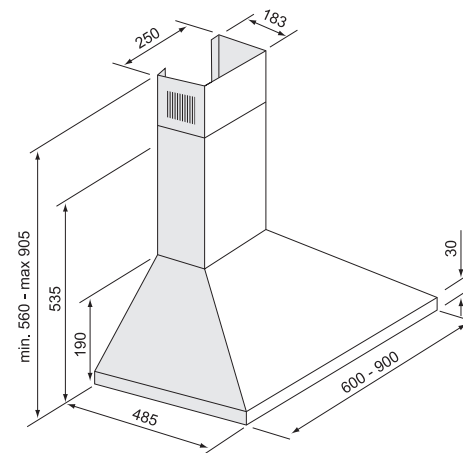

HBV60

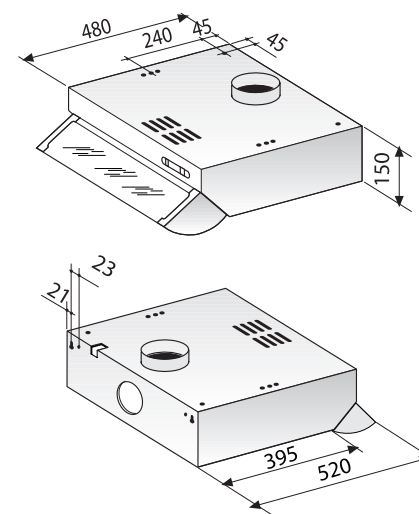

BEKO

BEKO

www.beko.co.uk

Beko plc. Beko House, Caxton Way, Watford, Hertfordshire WD18 8UF
Tel – 0845 6004904 Fax – 0845 6004925

Unit 16, The Hub Logistics Park Bracetown, Clonee Co. Dublin
Tel – 00353 18253700 Fax – 00353 18253705 www.beko.ie

Beko plc continuously seek improvements in specification, design and production of products and thus alterations take place periodically. Whilst every effort is made to produce up-to-date literature, this brochure should not be regarded as an infallible guide to current specification, nor does it constitute an offer for the sale of any particular appliance.